

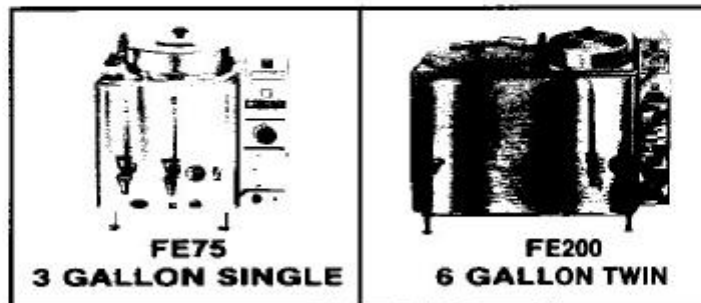

# AUTOMATIC COFFEE URNS



**FE75**  
**FE100**  
**FE200**  
**FE300**

## OPERATION MANUAL

### Contents

Specifications  
 Unpacking and Inspection  
 Installation  
 Brewing Instructions  
 Maintenance Tips  
 Repair Parts List  
 Wiring Diagrams

**CL75**  
**CL100**  
**CL200**  
**CH200**  
**CH100**  
**CH75**

### ELECTRICAL SPECIFICATIONS

Model No.	Kilowatts		Volts	Amps	
	1 Phase	3 Phase		1 Phase (3 wire)	3 Phase (4 wire)
FE75, CL75	7	6	120/240	29	15
	5.3	4.5	120/208	26	12
FE100	8	8	120/240	34	20
	6	6	120/208	29	17
CL100	7	8	120/240	29	20
	5.3	6	120/208	26	17
FE200, CL200	10	10	120/240	42	24
	7.5	7.5	120/208	38	22
FE300	—	15	120/240	—	37
	—	11.3	120/208	—	33

**Cecilware sells value... Worldwide.**

43-05 20th Avenue, Long Island City, NY 11105

• 718-932-1414  
 FAX: • 718-932-7860

N059A 9/01



**\*\* UNPACKING AND INSPECTION \*\***

**UNPACKING INSTRUCTIONS:** Carefully unpack urn and inspect immediately for shipping damage. Your automatic coffee urn was shipped in a carton designed to give it maximum protection in normal handling. It was thoroughly inspected before leaving the factory and the carrier accepted and signed for it. File any claims for shipping damage or irregularities directly with the carrier, not with the company.

**ASSEMBLY (See Illustration 3):** The four legs (38), faucets (36), vent cap drain (2) and water strainer assembly (23, 24) are packed separately with urn. Install legs by tilting urn on its side and screwing legs into urn leg supports until hand tight. Carefully right unit and install in its permanent location, being sure to leave at least 6" on right side of urn for access to controls. Level urn by adjusting legs. Then attach faucets and install vent cap drain.

Cover(s) (3) are shipped with knob(s) on inside to prevent damage. Simply unscrew and reverse knob(s) and hardware. Your urn comes with one brew basket (11) and an introductory filter pack. Additional Cecilware filters are available from your dealer.

**\*\* INSTALLATION INSTRUCTIONS \*\***  
**FOR QUALIFIED SERVICE PERSONS ONLY**

**CAUTION: DO NOT TURN THERMOSTAT ON UNTIL ALL INSTALLATION INSTRUCTIONS HAVE BEEN FOLLOWED.**

**WATER HOOK-UP (See Illustration 3):** Your urn comes supplied with a water strainer assembly (23, 24). Connect copper tubing (24) to elbow (22) at lower back of side box; then connect other end of water strainer to a suitable length of 1/4" tubing with shut-off valve (plumber supplied), connected to cold water supply.

The National Sanitation Foundation also requires an approved flowback prevention device such as a double check valve to be installed between urn and water supply. Adjust water pressure to 20 p.s.i. for proper operation.

**STEAM URNS**

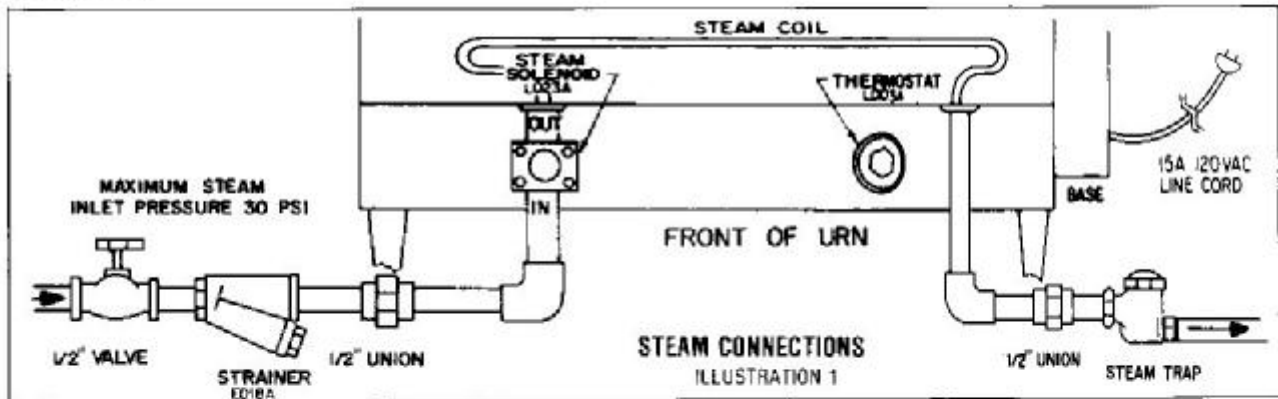

**SPECIFICATIONS**

Steam Inlet Pressure	15-30 p.s.i.
Steam Requirement	7-21 lbs./hr.
Plumbing Connection	1/2 n.p.t.
Electrical Connection	Plug line cord into any convenient 120V outlet
Input Power	120 VAC, 6A, 50/60 HZ

**TO PRIME: CAUTION: THERMOSTAT MUST BE IN THE "OFF" position.** Turn on water supply and electrical power to urn and wait until water is visible in center gauge glass (left-hand gauge glass on 3-gallon single urns). Priming can be accelerated by manual filling through vent cap opening in top of urn, using a water hose. Then turn thermostat knob (33, Ill. 3) to 10; thermostat pilot light shows heater is on. Urn jacket will continue to fill automatically until water reaches the proper level. When indicator on dial thermometer (32) approaches the "W" in BREW zone, 197°-205°F (92°-96°C), urn is ready to brew coffee. In high altitude locations (at least 5000 ft. above sea level), thermostat may have to be lowered to prevent boiling.

**NOTE: FOLLOW THE ABOVE INSTRUCTIONS FOR INITIAL PRIMING AND AFTER DRAINING URN FOR SERVICING.**

**TO BREW COFFEE:** Follow instructions on front of urn.

**ELECTRIC URNS**

All electric urns come wired single (1) or three (3) phase, except for the FE300 which is 3 phase only. See wiring diagrams. Illustration 6.

**1 Phase Hookup.** Remove screws and lift off side box door. Terminal block (20, Ill. 3) is located on rear wall of side box. Install a suitable conduit through knockout in rear of side box and connect No. 14 neutral wire to the center connection of terminal block (20). Then connect the remaining 2 wires to terminals L1 and L2.

**3 Phase Hookup.** 3 phase units have a 4-wire terminal block. Connect No. 14 neutral wire to end terminal marked NEUT and connect remaining wires to terminal L1, L2 and L3.

### RECOMMENDED WIRE SIZE FOR FIELD-WIRING URNS

Model No.	Wire Size	
	Single Phase	Three Phase
FE75, CL75, CL100	(2) 10 AWG	(3) 10 AWG
FE100	(2) 8 AWG	(3) 10 AWG
FE200, CL200	(2) 6 AWG	(3) 8 AWG
FE300	—	(3) 8 AWG

Neutral (N) and Ground Wires—14 AWG min.

NOTE: Field wiring must be suitable for 75° C. Use copper wire only for power supply connections.

**GROUNDING: ON ALL URNS, CONNECT A GROUND WIRE TO GROUNDING LUG (19) TO COMPLY WITH LOCAL ELECTRICAL CODES (14 AWG min. - 75°C).**

#### \*\* CORRECT PROCEDURES FOR BREWING COFFEE AS RECOMMENDED BY THE COFFEE BREWING CENTER \*\*

1. Use fresh urn grind or drip grind coffee . . . spread evenly on filter for proper extraction.
2. Urn should be connected to cold water supply and water heated to 197°-205°F (92°-96°C) before brewing coffee.
3. While brewing, leave cover on urn to preserve aroma and prevent excessive steaming.  
Total contact time for urn grind should be approximately 4-6 minutes.
4. Remove grounds and filter as soon as coffee has dripped through. Never pour coffee back through spent grounds.
- 5a. Urns with automatic agitator (FE and INS series) blend coffee automatically at end of brewing cycle. Press and hold agitator ON switch (31) for additional blending.
  - b. If urn has a manual agitator (CL series), press and hold agitator ON switch (31) for 15 seconds after brewing cycle to blend coffee.
  - c. On urns without agitator (CRS series), blend coffee by drawing off about half of batch and pouring back into brew (after removing grounds and filter).
6. Hold coffee at 185°-190°F (85°-88°C) (about 8 on thermostat). Brewed coffee should not be held for longer than one (1) hour and should never be reheated.

**SOLID-STATE TIMER ADJUSTMENT (ALL FE's):** A factory pre-set electronic solid-state timer controls the volume of water for each brew cycle. If more or less water is desired, follow these instructions.

Turn knob of timer (18, III.3) clockwise to increase volume of water or counterclockwise to decrease it. Run through a complete brew cycle after each adjustment. Since timer cannot be readjusted in mid-cycle, simply push cycle stop switch (25) at bottom right of side box if water gets too high. If maximum setting of timer fails to deliver enough water, check water pump and spray head and follow instructions under maintenance.

**NOTE:** The FE200 features a dual timer. The upper knob is factory-adjusted for a 1 lb. brew, the lower knob for the full 2 lb. brew.

**MECHANICAL TIMER ADJUSTMENT (ALL CL's):** The factory pre-set mechanical timer can be adjusted for more or less water by following these instructions:

Remove timer knob and loosen lock nut holding stop pin. To increase volume of water, rotate stop pin clockwise. To decrease, rotate counterclockwise. Tighten lock nut and replace knob.

**SPRAY ARM BY-PASS ADJUSTMENT (ALL FE's, INS's, CL200 and CRS66) (See III. 2):** Adjustable bypass allows proper brew extraction even with variations caused by soft or treated water. If bypass requires adjustment to correct for local water conditions, proceed as follows:

Position spray head over center of coffee liner and press BREW switch. Turn by-pass adjustment screw clockwise to decrease by-pass flow (for stronger coffee) or counter-clockwise to increase it (for less strong coffee). At end of brewing cycle, note volume of water in coffee liner. Readjust timer if necessary to obtain the correct volume of water.

**THERMOSTAT ADJUSTMENT:** To adjust temperature of water in urn jacket (205°F or 96°C), turn thermostat knob (33, III. 3) to 10 (maximum clockwise position). Pull off knob and insert a small screwdriver into adjusting screw in center of shaft when temperature on dial thermometer (32) approaches the "W" in the word BREW. Slowly rotate screw clockwise until thermostat pilot light goes out. Turning screw clockwise lowers temperature and turning counter-clockwise raises it. Apply a sealer (glyptol or fingernail polish) to screw after adjustment has been made.

#### \*\* MAINTENANCE TIPS \*\*

**SPRAY ARM ASSEMBLY:** The new improved spray head system was designed to facilitate easier cleaning and maintenance. The swivel valve has a larger flow opening and the spray head cap is equipped with a stainless steel disc, used to control the flow of water.

When ordering replacement parts, be sure to order the correct disc and spray cap for each urn, as shown in Illustration 2.

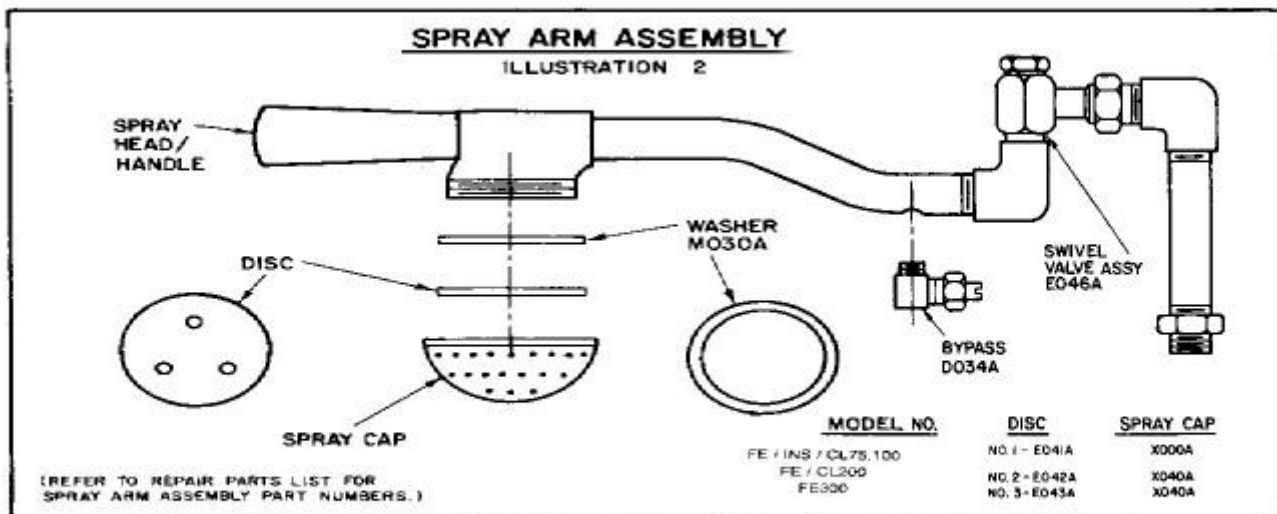

To prevent lime buildup, especially in hard water areas, remove and clean spray head cap and spray head disc frequently. To clean swivel valve (see III. 2) loosen nut and remove spray arm assembly from urn. Remove sediment by inserting a pipe cleaner through small hole in valve. If maximum setting of timer (18, III. 3) fails to deliver enough water, check water pump (28).

**FOR QUALIFIED SERVICE PERSONS ONLY**

**CAUTION: DISCONNECT POWER BEFORE ATTEMPTING ANY ELECTRICAL REPAIRS.**

**IF WATER FAILS TO HEAT:**

1. Check line fuse or circuit breaker. Replace or reset if necessary.
2. Make sure thermostat is in ON position. If thermostat pilot light does not come on, replace thermostat (21, III. 3). (Refer to instructions below.) If pilot light is on, measure continuity between terminals 1 and 2 of thermostat, and between terminals 3 and 4. (See III. 6) If a resistance is measured, replace thermostat.
3. If thermostat is okay, check wiring and repair if necessary; if wiring is okay, check heater resistance; if high or infinite, replace as follows:

**REPLACING HEATER (See III. 3):**

1. Shut off power and disconnect water supply at elbow (22, 111. 3). Drain urn.
2. Remove one coffee gauge glass (37), faucet (36), shank (37), and liner (12).
3. Tilt urn and disconnect wires to heater (34).
4. Remove socket head screw and heater flange and lift heater out.
5. Install new heater and reassemble urn.
6. Repeat priming instructions on page 2. **CAUTION: DO NOT TURN ON THERMOSTAT UNTIL URN IS PRIMED.**

**REPLACING THERMOSTAT (FE200, FE250, FE300):**

1. Shut off power, disconnect water supply, and drain urn.
2. Tilt urn and check wiring underneath before removing thermostat. If wiring seems to be in good condition, proceed as follows:
3. Remove thermostat knob (33, III. 3) and two screws holding thermostat in place.
4. Disconnect wires from thermostat.
5. Unscrew packing nut and pull out thermostat bulb.
6. Install new thermostat.
7. Repeat priming instructions on page 2. **CAUTION: DO NOT TURN ON THERMOSTAT UNTIL URN IS PRIMED.**

**REPLACING THERMOSTAT (All Other Models):** Thermostat is located in side box instead of skirt of urn. Lift off side box door to gain access to thermostat; then follow instructions above.

**IF WATER FROM COLD WATER SUPPLY LINE DOES NOT ENTER URN:**

1. Check water supply to external shut-off valve and water strainer (23, III. 3).
2. Check fuse (30) on front of side box and replace if necessary.
3. If water supply and fuse are okay, remove fuse and lift off side box door. Remove timer (18), exposing terminal block (16) (see III. 5) and electrical wiring.

4. Place wire jumper across terminals 8 and 9 of terminal block (III. 5). Reinstall fuse. If water enters urn, replace float switch (3), as explained below. If no water enters urn, solenoid (27) or small relay (14) is not functioning. To check solenoid, remove fuse and disconnect leads from coil; then reinstall fuse. If solenoid makes buzzing sound, replace relay. If no sound, replace solenoid.

#### **REPLACING SOLENOID (27, III. 3):**

1. Shut off water supply, remove fuse (30), and lift off side box door.
2. Disconnect wires from solenoid; then remove flare nut and unscrew solenoid valve from bracket.
3. Install new solenoid and reinstall fuse and side box door.
4. If necessary, follow priming instructions on page 2.

#### **REPLACING FLOAT SWITCH (17, III. 3):**

1. Remove fuse (30), lift off side box door, and remove timer (18) from bracket, exposing terminal block (16) and electrical wiring.
2. Disconnect float switch wires from terminals 8 and 9 on terminal block (see III. 5).
3. Unscrew packing nut from bottom of float can (13) and remove float switch (17) by pulling on wires.
4. Replace with new float switch and reassemble unit in reverse order.

**CLEANING FLOAT CAN ASSEMBLY (13, III. 3):** Periodically it may become necessary to clean float can (13, III. 3) to keep float switch (17) operating properly.

1. Remove float can cover (10) and lift float (9) from stem.
2. Clean container and float, replace float on stem and reinstall cover.

#### **IF WATER RUNS OUT AT OVERFLOW DRAIN (40, III. 3):**

1. Make sure urn is level and overflow tube (45) is vertical.
2. Remove fuse (30) from front of side box. If water stops, replace float switch (instructions above).
3. If water continues to flow, solenoid valve is dirty or not seating properly. Replace solenoid as described above.

#### **NO WATER FROM SPRAY HEAD (1, III. 3):**

1. Check fuse (30) first.
- 2a. For all urns except CL's: Depress BREW switch (29) and release. If switch remains lit, water pump (28) is probably not operating. Lift off side box door and check if fan on water pump is rotating. If not, replace pump as described below.
- b. For CL urns: Turn brew timer knob clockwise. Replace timer if it does not go on. If timer goes on but pump doesn't, replace pump. (See bottom left box of III. 5.)

#### **REPLACING WATER PUMP (28, III. 3):**

1. Shut off water supply and remove fuse (30). Drain urn to level of water faucet.
2. Lift off side box door and disconnect the two pump wires (see III. 5).
3. Loosen union fittings on pump and remove pump from urn.
4. Replace pump and follow priming instructions on page 2.

**CHECKING SOLID-STATE TIMER (18, III. 3) (ALL URNS EXCEPT CL'S):** Press and hold BREW switch (29) for 10 seconds. Brew cycle should start. If water stops coming from spray head as soon as BREW switch is released, timer is not operating. Replace it. (Instructions below.) If no water comes from spray head when BREW switch is pressed, replace switch.

**NOTE:** To check mechanical timer on CL urns, refer to NO WATER FROM SPRAY HEAD, (see para. 2b above).

#### **REPLACING SOLID-STATE TIMER (See III. 5):**

1. Remove fuse (30, III. 3), lift off side box door, and remove timer from bracket.
2. Carefully note locations of colored wires on timer board, then remove wires.
3. Replace timer and reassemble unit in reverse order.

#### **AGITATOR - AUTOMATIC TYPE (ALL FE AND INS URNS):**

##### **OPERATION:**

The agitator pump circuit is programmed to operate immediately after brewing cycle. The circuit pumps air through the coffee gauge glass(es) into the coffee liner(s). The complete cycle takes about 20 seconds. For additional blending, simply press the agitator ON switch (31, III. 3).

##### **MAINTENANCE:**

If agitation is not sufficient to blend coffee, check flexible tubing (6 and 44), and glasses and fittings, for possible air leaks. Replace as necessary.

If agitator pump (5) does not operate immediately after brewing cycle or when agitator ON switch (31) is pressed, replace agitator pump or solid state agitator timer (8).

If agitator pump comes on immediately after brewing cycle, but does not operate when agitator ON switch is pressed, replace agitator ON switch.

**AGITATOR - MANUAL TYPE (CL URNS)****OPERATION:**

Immediately after brewing cycle, depress agitator ON switch and hold for about 20 seconds. Your coffee will be completely blended and ready to serve.

**MAINTENANCE:**

If agitator pump does not operate when agitator ON switch is pressed, replace switch. If pump still does not operate, replace pump.

**REPAIR PARTS LIST**

(See Illustration 3)

ITEM NO.	STOCK NO.	DESCRIPTION	MODEL NO.
1	E045A	Complete spray arm asm. w/bypass	FE/INS/CL75, 100
1	E011A	Complete spray arm assembly	CRS3, 33
1	E036A	Complete spray arm asm. w/bypass	FE/CL200, FE250, CRS66
1	E039A	Complete spray arm assembly	FE300
2	U019A	Complete spray arm asm. w/bypass	All (except INS's)
2	E072A	Vent cap drain	All INS's
3	Q024A	Vent cap drain	FE/INS/CL75, 100; CRS3, 33
3	Q011A	Cover with knob	FE/CL200; FE250; CRS66
3	Q092A	Cover with knob	FE300
4	E023A	3" Nipple union assembly	All (except FE300)
4	E036A	3" Nipple union assembly	FE300
5	CS11A	Agitator pump assembly	All (except CRS's)
6	H050A	9 5/8" Agitator tubing	All (except CRS's)
7	U152A	Agitator box cover	All (except CRS's)
7	L249A	Agitator asm. (solid state aut.)	All FE's and INS's
7	L251A	Agitator assembly (manual)	All CL's
8	L238A	Solid state agitator timer	All (except CRS's)
9	E040A	Float	All
10	U022A	Float can cover	All
11	V002A	Brew basket (s/s)	FE/INS75, 100, CRS3, 33
11	V002A	Brew basket (s/s)	FE/CL200; FE250; CRS66
11	V061A	Brew basket (s/s)	FE300
11	V113A	Brew basket (polypropylene)	CL75, 100
12	Q062Q	Liner - 3 gallon	FE/INS/CL75, 100; CRS3, 33
12	Q094Q	Left liner - 9 gallon	FE300
12	Q095Q	Right liner - 9 gallon	FE300
12	Q096Q	Left liner - 6 gallon	FE/CL200; FE250; CRS66
12	Q097Q	Right liner - 6 gallon	FE/CL200; FE250; CRS66
13	U023Q	Float can assembly	All
14	L018A	Relay	All
15	C006A	Capacitor & resistor asm.	All
16	B034A	Terminal block	All
17	L019A	Float switch	All
18	L205A	Solid state timer 120V	All (except FE200 and CL's)
18	L210A	Solid state timer 220V	All (except FE200 and CL's)
18	L214A	Dual solid state timer 120V	FE200
18	L216A	Dual solid state timer 220V	FE200
18	L154A	Mechanical timer (Not shown)	All CL's
19	B039A	Grounding lug	All
19	C034A	Contactor (Not shown)	FE300
20	B000A	Terminal block	All single phase
20	B017A	Terminal block	All three phase
21	L029A	Thermostat	All
22	K026A	Elbow	All
23	E002A	Water strainer	All
24	H016Q	1 1/2" Copper tubing	All
25	C396A	Fuse holder, SC-6 type	All
25	C142A	Fuse holder, FN type (Canadian)	All
26	L017A	Cycle stop switch	All (except CL's)
27	L022A	Solenoid .28 GPM	FE/INS/CL75, 100; CRS3, 33
27	L010A	Solenoid .50 GPM	FE/CL200; FE250; CRS66
27	L060A	Solenoid .75 GPM	FE300
27	X008A	Solenoid coil	All
27	X035A	Solenoid diaphragm repair kit	All
27	X035A	Solenoid flow washer (Not shown) .26	FE/INS/CL75, 100; CRS3, 33
27	X036A	Solenoid flow washer (Not shown) .5	FE/CL200; FE250; CRS66
27	X038A	Solenoid flow washer (Not shown) .75	FE300
28	E000A	G-water pump	All
28	E000T	Rebuilt G-water pump	All
28	U070A	G-water pump fan	All
28	E059A	H-water pump	All
28	X032A	Seal kit for G-water pump	All
29	L012A	BREW switch	All (except CL's)
30	C395A	Fuse 5A SC-6	All
30	C141A	Fuse, SAFN (Canadian)	All
31	L236A	Agitator	All (except CRS's and CL's)
31	L052A	Agitator	All CL's
32	L007A	Dial thermometer	All (except INS's)
32	L323A	Dial thermometer	All INS's
33	M006A	Thermostat knob	All
34	G013A	Water heater 8kw-240V-1Ph	FE/INS100; CRS33
34	G031A	Water heater 7kw-240V-1Ph	FE/INS/CL75; CRS3; CL100
34	G011A	Water heater 5kw-240V-1Ph	FE/CL200; FE250; CRS66; FE300
34	G026A	Water heater 8kw-240V-3Ph	FE/INS/CL100; CRS33
34	G024A	Water heater 6kw-240V-3Ph	FE/INS/CL75; CRS3
34	G018A	Water heater 5kw-240V-3Ph	FE/CL200; FE250; CRS66
34	G040A	Water heater 5kw-480V-3Ph	FE/CL200; CRS66; FE250, 300

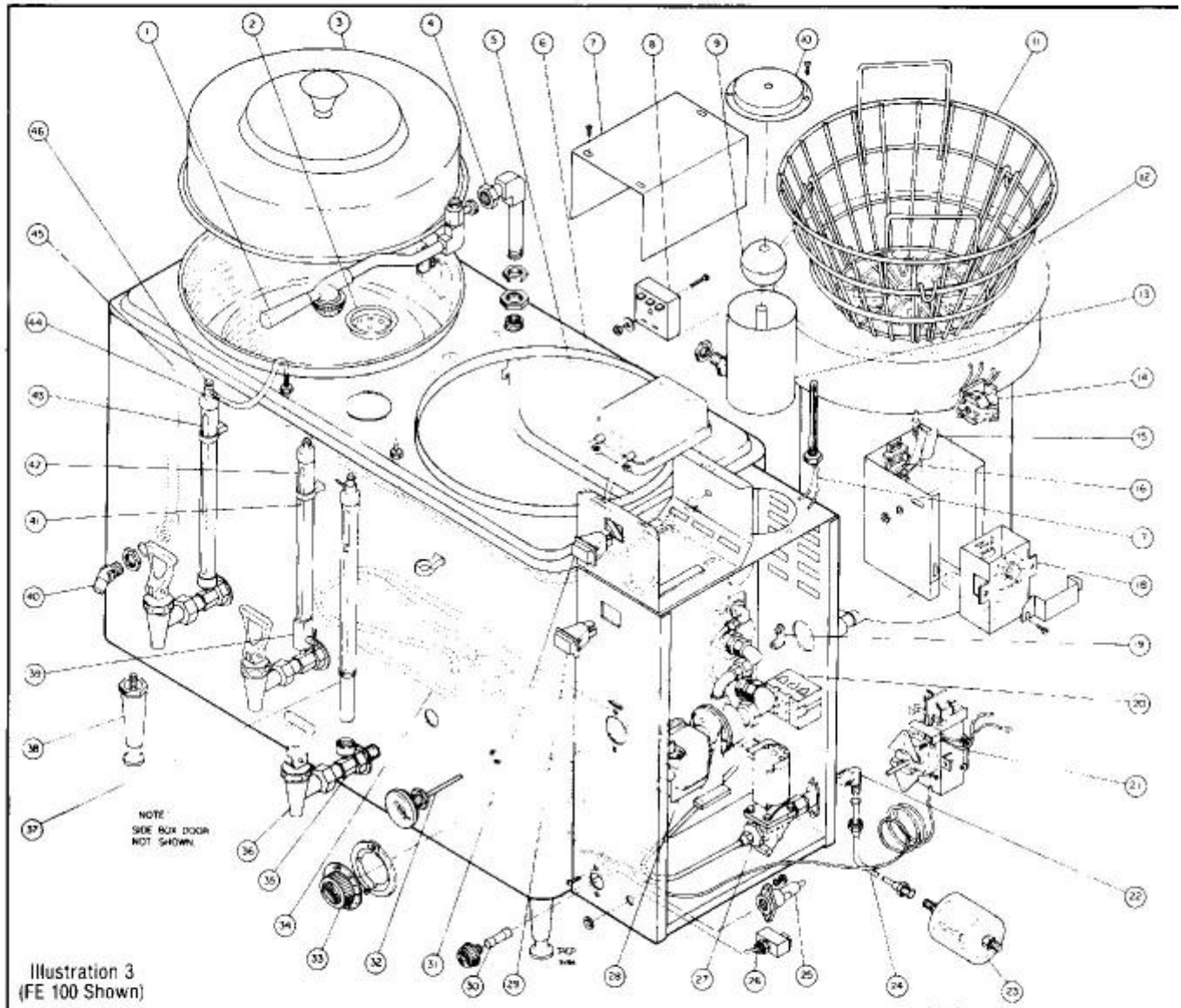

ITEM NO.	STOCK NO.	DESCRIPTION	MODEL NO.
34	G043A	Water heater 8kw-480V-3Ph	FE/INS/CL75, 100, CRS3, 33
35	D021A	Shank for coffee gauge	All (except INS's)
35	D045A	Shank for gauges	All INS's
36	D017A	Water and coffee faucet	All
37	X005A	Coffee gauge glass	FE/INS/CL75, 100, CRS3, 33
37	X004A	Coffee gauge glass	FE/CL200; FE250, CRS66
37	X044A	Coffee gauge glass	FE300
38	M005S	Legs, chrome	All (except CL's)
38	M172S	Legs, black	All CL's
39	D022A	Shank for water gauge	All (except INS's)
40	E009A	Overflow drain	All (except INS's)
40	E071A	Overflow drain	All INS's
41	X006A	Water gauge glass	FE/INS/CL75, 100, CRS3, 33
41	X030A	Water gauge glass	FE/CL200; FE250, CRS66
41	X043A	Water gauge glass	FE300
42	D024A	8" or 8½" Water gauge shield	FE/INS/CL75, 100, CRS3, 33
42	D001A	9" Water gauge shield	FE/CL200; FE250; CRS66
42	D032A	12" Water gauge shield	FE300
43	D001A	9" Coffee gauge shield	FE/INS/CL75, 100, CRS3, 33
43	D020A	10-¼" Coffee gauge shield	FE/CL200; FE250; CRS66
43	D031A	14½" Coffee gauge shield	FE300
44	H051A	5" Agitator Tubing	All (except CRS's)
45	H025Q	Overflow tube	All
46	K108A	Vent cap assembly	All (except CRS's)
	718	Filter pack (Not shown)	FE/INS/CL75, 100, CRS3, 33
	820	Filter pack (Not shown)	FE/CL200; FE250; CRS66
	923	Filter pack (Not shown)	FE300

# WIRING DIAGRAMS

ILL. 4 - SCHEMATIC DIAGRAM - 120/208V OR 120/240V  
50/60 HERTZ  
1 PHASE, 3 WIRE OR 3 PHASE, 4 WIRE

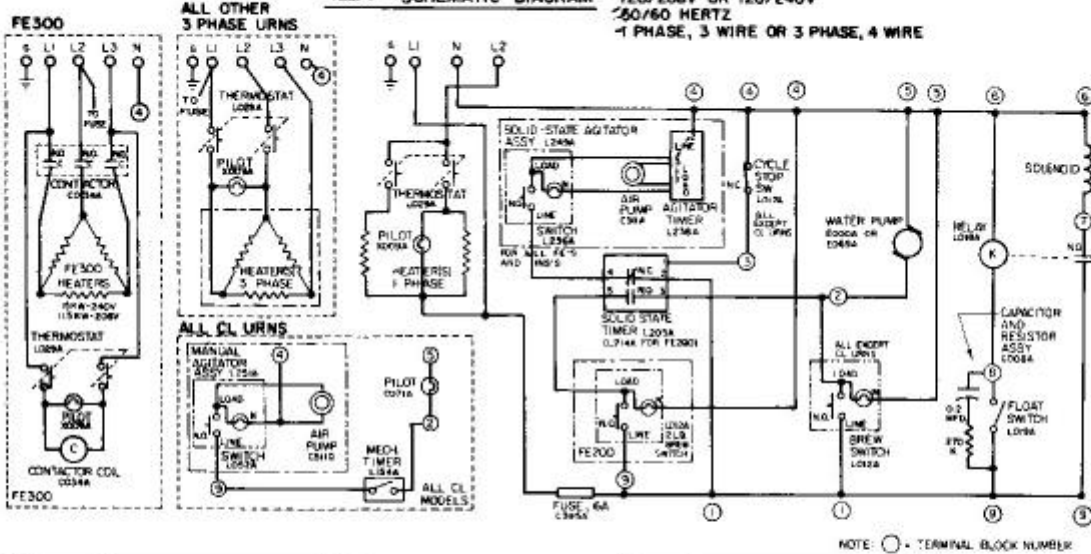

ILL. 5 - SIDE BOX WIRING DIAGRAM - ALL URNS

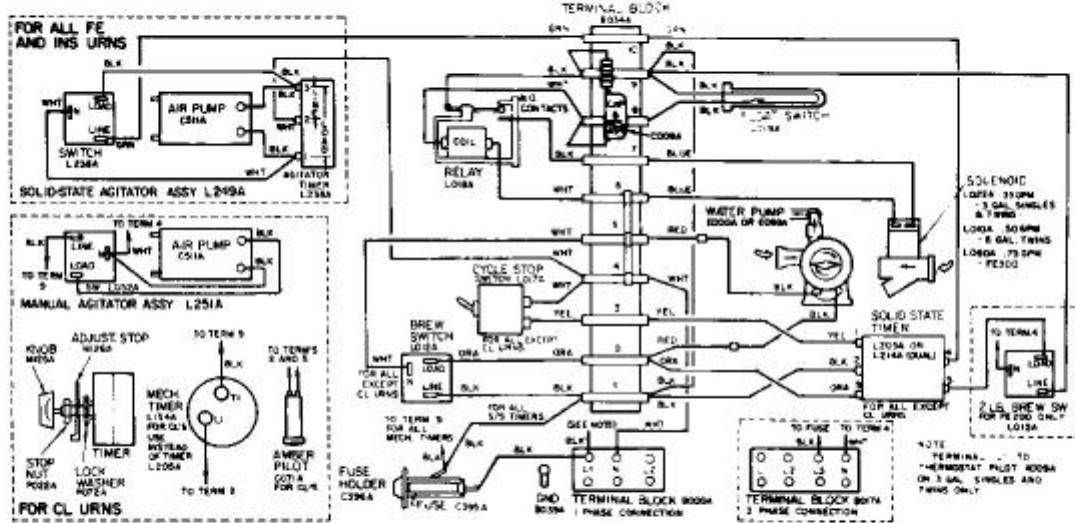

ILL. 6 - POWER WIRING DIAGRAMS

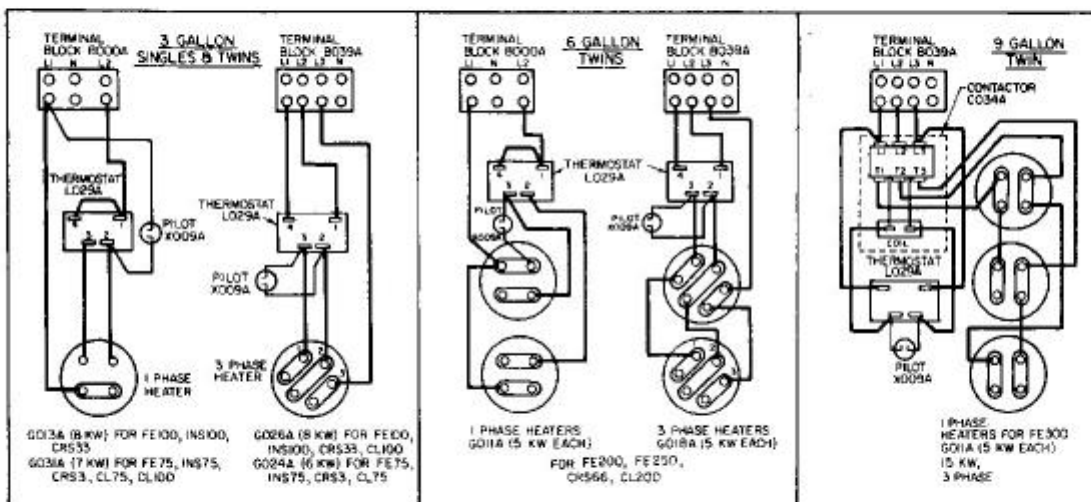



220 V.

DATE

MODEL NO: CL-100 / FE-100 / CRS-33 / FD-404

KW (TOTAL) 6.7 VOLTS 220 AMPS 31.4 PHASE

NO OF ELEMENTS 1 KW/ELEMENT 8 VOLTS/ELEMENT

THERMOSTAT D-1 PILOT 240 VOL

CONTACTOR COIL VOLTS

TRANSFORMER VOLTS

SIDE BOX VOLTS 220

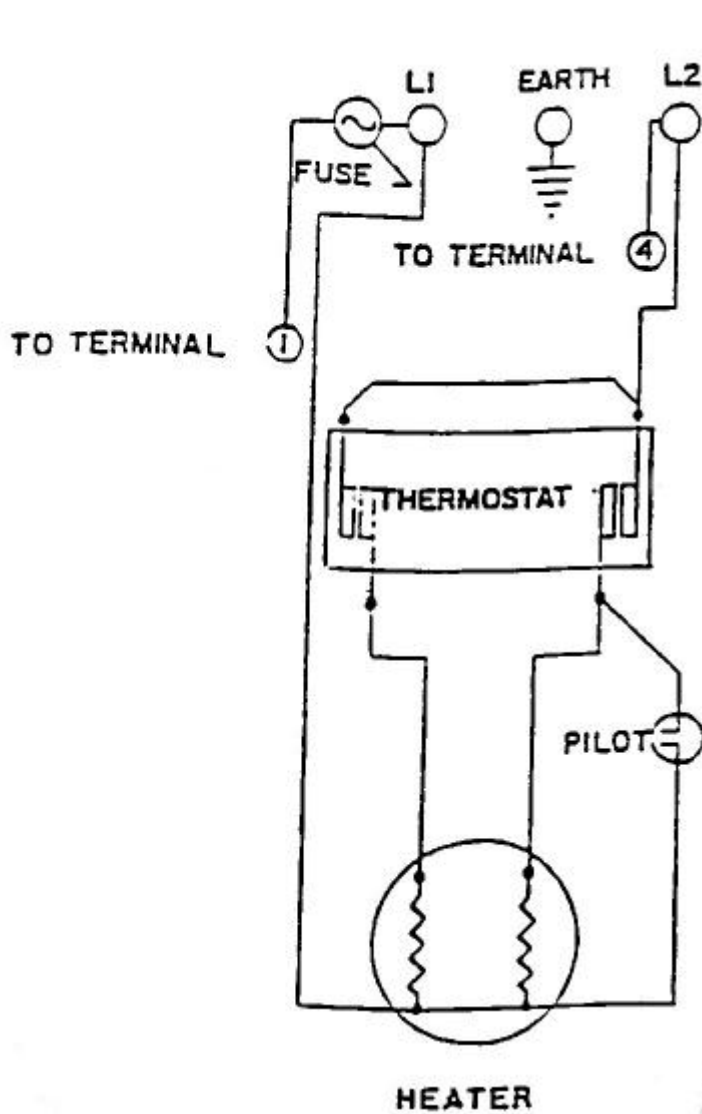

FE100

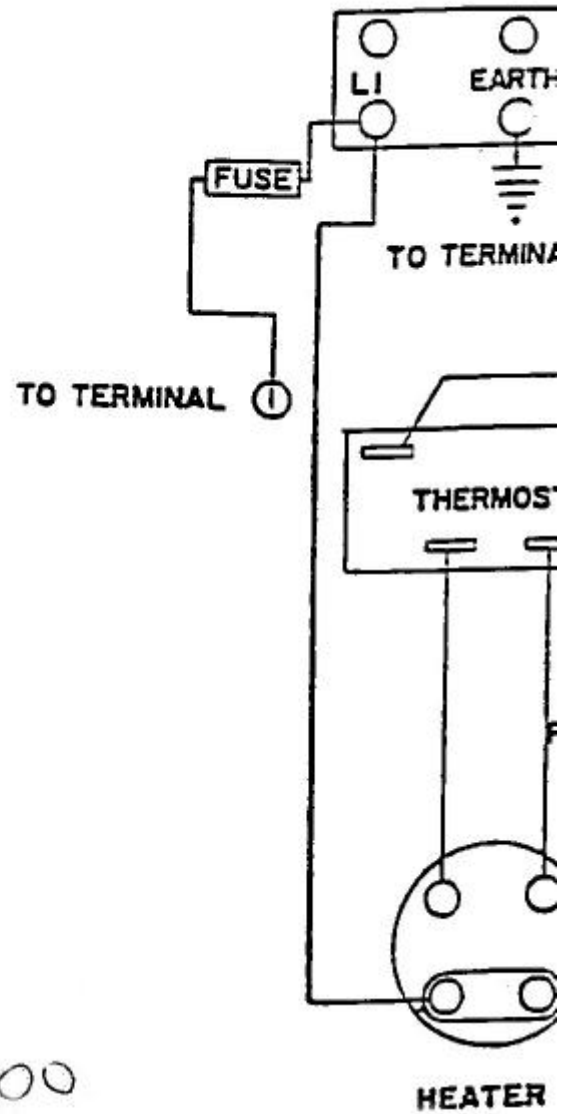

MODEL NOS:

- CL-100
- FE-100

