



Ice Machine Parts List for Series i-1000 Models

iD1002A

iY1004A

iD1003W

iY1005W

iD1092N

iY1094N

JC0995

i1000 CONTROL BOX

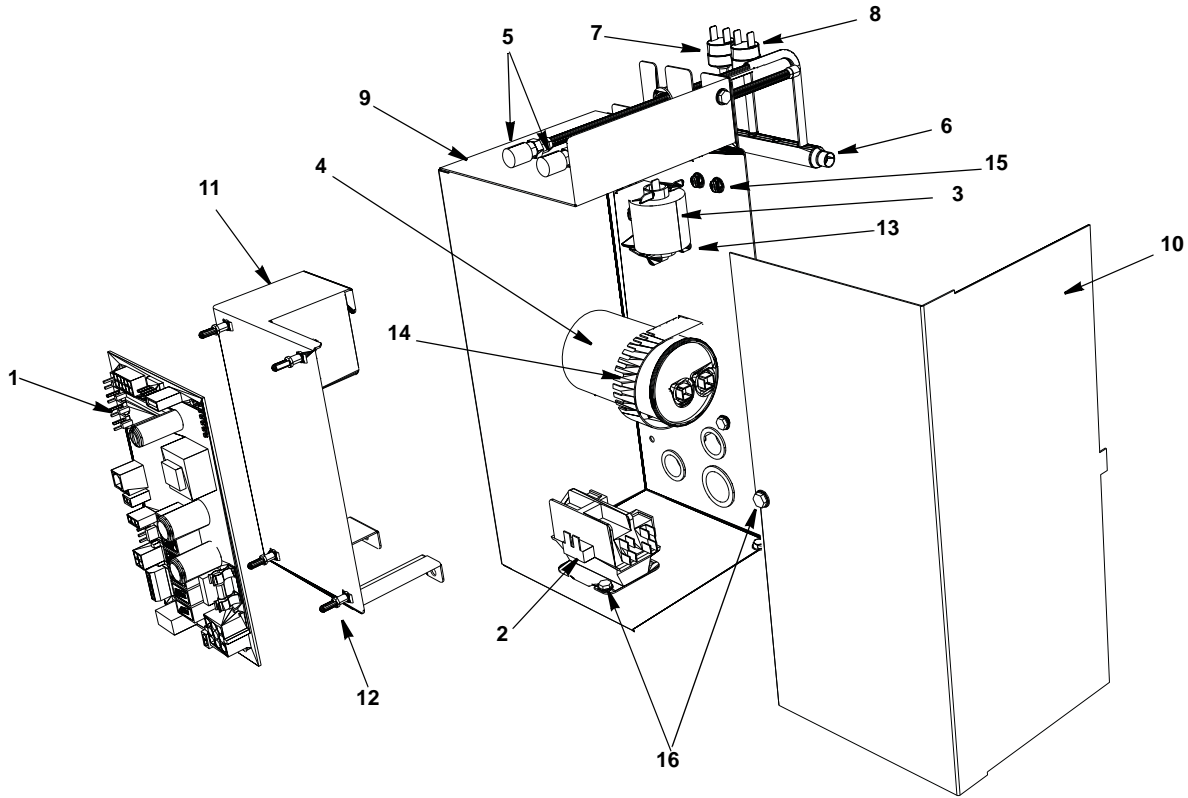

DESCRIPTION

DESCRIPTION	PART NO.
1 Control Board (for use with all voltages)	000008309
a. 8 amp Ceramic Fuse – Mounted on Control Board	000009181
2 Contactor	
a. 208-230V/60 Hz/1ph or 230V/50 Hz/1ph	20-0659-9
b. 208-230V/60 Hz/3ph	20-0661-9
3 PTCR Compressor Starter	85-0499-3
4 Compressor Run Capacitor	
a. 208-230V/60 Hz/1ph	85-0393-3
b. 208-230V/50 Hz/1ph	000001395
5 Refrigeration Service Valve Assembly	83-7326-3
6 Manifold Strainer	82-5104-9
a. Bracket	605857-1
7 High Pressure Cut-out (Auto Reset)	20-0124-3
8 Fan Cycling Control	† 20-0127-3
Miscellaneous – Brackets, Screws, etc.	
9 Control Box	000007563
10 Control Box Cover	000007569
11 Control Board Mounting Bracket	000007564
12 Control Board Mounting Supports	43-0225-3
13 PTCR Compressor Starter Mounting Bracket	85-0501-3
14 Capacitor Mounting Strap	602495-3
15 Screws, #10-24 x .50 Ground	52-0216-9
a. Star Washer	55-7320-9
16 Screw, #10-24 x .50	52-0206-9
17 Lockwashers	55-7320-9
18 Control Box Bushings	
a. Large (1)	25-0001-9
b. Small (4)	25-0140-9
19 Control Box Wiring Harness (Not shown)	
a. 230/60/1	000007179
b. 230/60/3	000007181
c. 230/50/1	000007180
d. 460/60/3	000008020
e. Harvest Air Assist Pump	20-0743-9
20 Compressor Compartment Wiring Harness (Not shown)	
a. Air-cooled	000007178
b. Water-cooled	000007176
c. Remote-cooled	000007175
21 Electrical Noise Filter Wiring Harness	
a. 460/60/3	000005500

i1000 EVAPORATOR COMPARTMENT - COMMON COMPONENTS

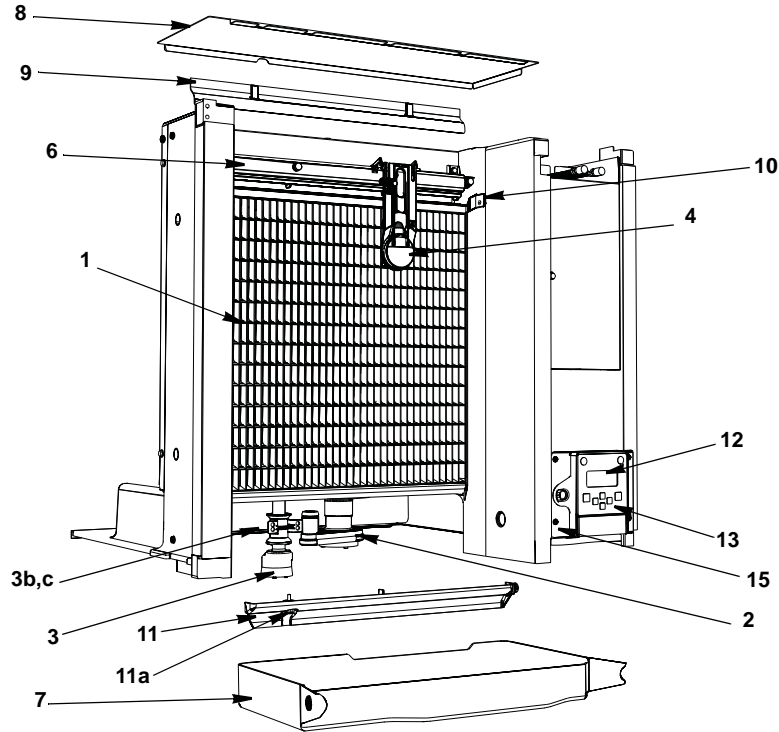

DESCRIPTION

	DESCRIPTION	PART NO.
1	Evaporator Assembly	
	a. Dice Cube	76-0228-3
	b. Half Dice Cube	76-0227-3
2	Water Pump	
	a. 230V/60 Hz 1/3PH	82-5113-9
	b. 230/50/1	82-5270-9
3	Water Level Probe.	000007052
	a. Wire, control box to probe (Not shown).	000007724
	b. Holder	000007053
	c. Screw (Mount Water Level Probe Holder)	52-0209-9
4	Ice Thickness Control Probe.	000008660
5	Water Curtain (Not shown)	40-1098-9
6	Water Distribution Tube Assembly	76-0219-3
	a. O-Rings (Back of Distribution Assembly)	50-0464-9
7	Water Trough	40-0360-9
8	Foodzone Seal Panel	000007613
9	Evaporator Top Filler Panel	40-0846-9
	a. Stainless Steel Clamp	606333-9
	b. Clamp Screw.	52-0209-9
10	Evaporator Top Frame Assembly	76-0220-3
11	Water Diverter.	76-0221-3
	a. Thumbscrew	53-0512-3
12	LCD Display	000006728
13	Touch Pad with Housing	000007926
14	LCD Wiring Harness (Not shown).	000007737
15	Touch Pad/Housing Mounting Bracket	000006697
16	Front Panel LCD Frame	
	a. With Key Guard.	000006647
	b. Without Key Guard	000006564
	c. Display Cover (hides the display completely)	K00433
17	Ice Deflector (Not shown)	000006700
Miscellaneous – Brackets, Screws, etc.		
18	Screw, (Water Distribution Tube Mounting) Each	50-0479-9
	a. O-Ring.	50-0462-9
19	Screw, #12-16 x .687 Used to Mount Evaporator (Each)	50-0461-9
20	Water Pump Base O-Ring	50-0465-9
21	Water Pump Outlet O-Ring.	50-0467-9

i1000 REFRIGERATION COMPARTMENT – COMMON PARTS

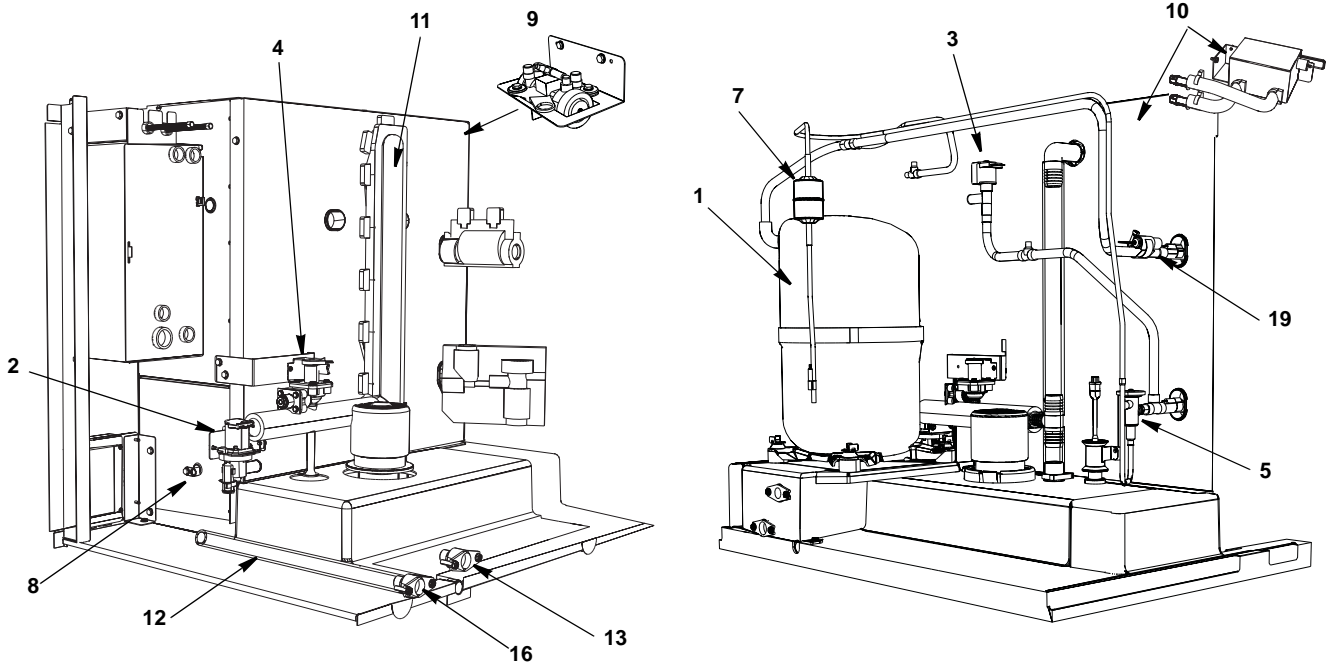

DESCRIPTION

		PART NO.
1	Compressor	
	a. 208-230V/60 Hz/1 Ph	000007748
	b. 208-230V/60 Hz/3 Ph	000007749
	c. 230V/50 Hz/1 Ph	000007750
	d. Molded Plug	000005176
2	Water Dump Valve (with bracket)	
	a. Dump Valve, 208-230V/50-60 Hz	000001768
	b. Mounting Bracket	605845-9
	c. Dump Valve Tubing 3.25 inches	44-2038-3
3	Harvest Valve	
	a. Harvest Valve Including 208/230V 50/60 Hz Electrical Coil	000007015
	b. Harvest Valve 208/230V Coil Only Danfoss	000005157
4	Water Inlet Valve	
	a. Water Inlet Valve Including 208-230V/50-60 Hz Coil	000007966
	b. Water Inlet Valve Bracket	000007594
5	Expansion Valve	
	a. Expansion Valve Body Insulation Boot	40-0036-3
	b. Expansion Valve Bulb Insulation Boot	40-0720-3
6	Thermistors with Spring Clips	000008310
7	Drier	89-3025-9
8	Magnetic Bin Switch	000007710
	a. Wiring Harness	000007410
9	Air Assist	
	a. 230V with brackets	000007223
	b. Manifold Tee (Air Pump Tubing Outlet)	40-1173-9
	c. Bracket	000006489
	d. Nozzle	30-0145-3
10	LuminIce	
	a. LuminIce Bulb	K00424
	b. LuminIce Wiring Harness	K00425
	c. Bulkhead Fitting 2.25"	000007409
	d. Bulkhead Fitting 2.75"	000007990
11	Insulated Tube (vinyl tubing from distribution tube to water pump & dump valve)	000008269
	a. Clamp 0.859/0.989 ID	000003406
	b. Clamp 0.799/0.899 ID	56-5060-3
12	Vinyl Tubing 0.625 ID (dump valve to drain adapter)	56-5070-3
	a. Insulation	000001382
	b. Clamp	603883-1
		56-5070-9
Miscellaneous – Brackets, Screws, etc.		
13	Water Inlet Wing Adapter	87-0609-3
	a. Adapter Plastic Fitting	13-6096-1
14	Water Inlet Valve Tubing	40-1043-9
15	Connector Water Inlet Valve	13-6098-9
16	Water Drain Wing Adapter	87-0613-3
17	Compressor Mounting	
	a. Base	606170-9
	b. Rubber Grommet	85-0306-9
	c. Sleeve	85-0394-9
	d. Bolt	50-0481-9
	e. Nut	50-0482-9
18	Clamp, Expansion Valve Bulb	56-5052-9
19	Copper Bulb Strap	30-0050-3
20	Screw, #10-24 x .50	52-0206-9

i1000 Refrigeration Compartment – Air-Cooled

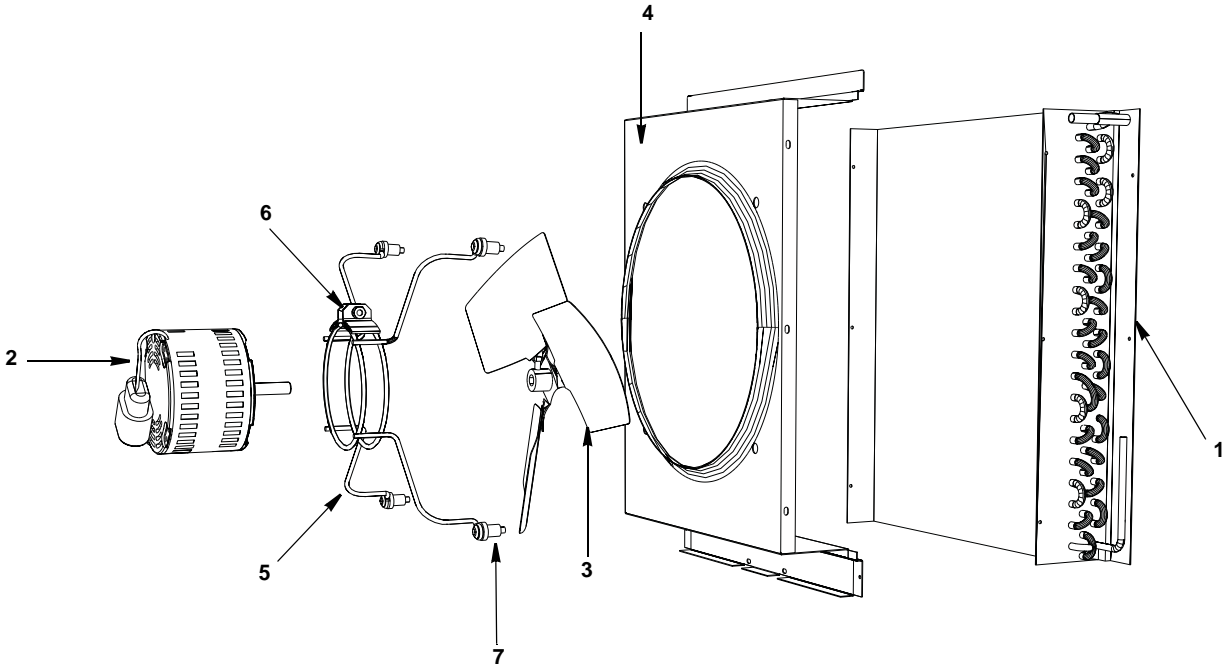

DESCRIPTION

	DESCRIPTION	PART NO.
1	Air Condenser	82-5239-9
2	Fan Motor (208-230V/60 Hz or 230V/50 Hz)	000003033
3	Fan Blade	24-1612-3

Miscellaneous – Brackets, Screws, etc.

4	Fan Shroud	605811-9
5	Fan Motor Bracket	30-0684-3
6	Fan Motor Mounting	
	a. Screw	† 50-3358-9
	b. Lockwasher	† 55-4510-9
	c. Hexnut	† 54-2952-9
7	Fan Bracket Mounting	
	a. Screw	50-3238-9
	b. Lockwasher	† 55-4510-9
	c. Flatwasher	† 55-7305-9
	d. Rubber Wellnut	† 54-2955-9
8	Screw, #10-24 x .50	† 52-0206-9

† Refer to Cross Reference Guide

i1000 REFRIGERATION COMPARTMENT – WATER-COOLED

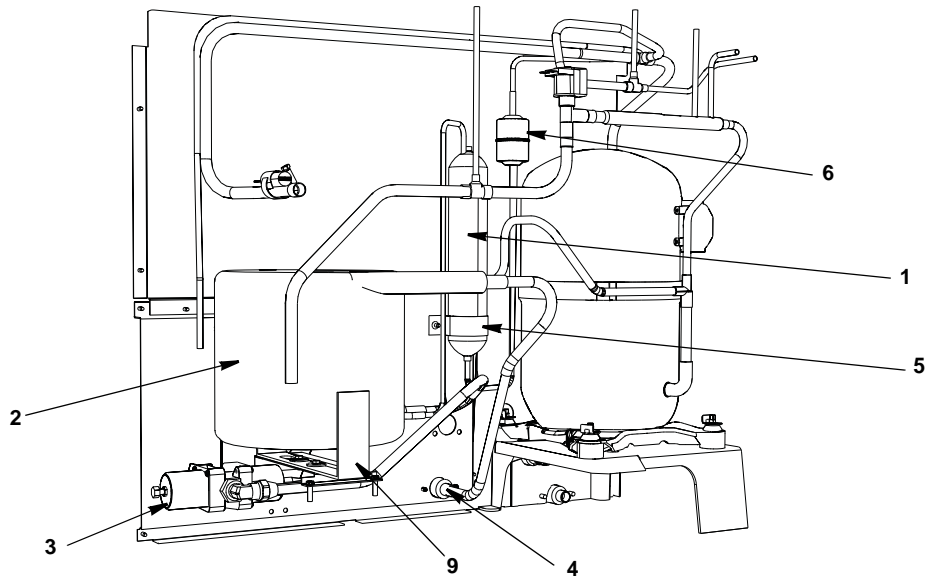

DESCRIPTION

	PART NO.
1 Receiver	89-0012-3
2 Water-cooled Condenser	† 000001507
3 Water Regulating Valve	000007546
4 Condenser Water Drain Female Wing Adapter	87-0608-3

Miscellaneous – Brackets, Screws, etc.

5 Receiver Strap	600054-1
6 Elbow .50 MF x .375 MPT	50-0224-9
7 Screw, #10-24 x .50	52-0206-3
8 Washer	55-7341-9
9 Base, Water Condenser/Receiver	605865-9

† Refer to Cross Reference Guide

i1000 REFRIGERATION COMPARTMENT – REMOTE

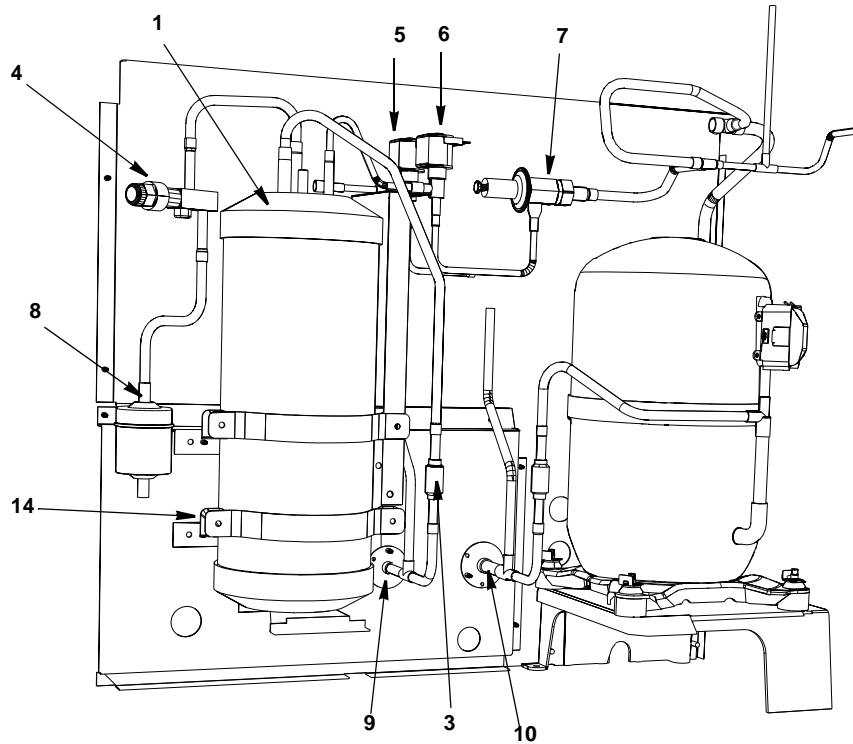

DESCRIPTION

	DESCRIPTION	PART NO.
1	Receiver	76-2957-3
2	Drier	89-3027-9
3	Magni-Check Valve	† 83-7314-9
4	Refrigeration Service Valve	† 83-7316-9
	a. Cap for Refrigeration Service Valve	56-5075-9
5	Harvest Pressure Regulating Solenoid (HPR) Valve	
	a. HPR Valve Including 208/230V 50/60 Hz Electrical Coil (Danfoss)	000007034
	b. HPR Valve 208/230V 50/60 Hz Coil Only Danfoss	000005157
6	Liquid Line Solenoid (LLS) Valve	
	a. LLS Valve Including 208/230V 50/60 Hz Electrical Coil (Danfoss)	000007032
	b. LLS Valve 208/230V 50/60 Hz Coil Only Danfoss	000005157
7	Harvest Pressure Regulating Valve (HPR)	† 83-6779-3
8	Drier	89-3027-9
9	Coupling – Male, 5/8-18	† 83-6034-3
10	Coupling – Male, 1-1/6-12	† 83-6035-3
Miscellaneous – Brackets, Screws, etc.		
11	Coupling Mounting Flange for 5/8-18	83-6005-3
12	Coupling Mounting Flange for 1-1/16-12	83-6006-3
13	Drier Support Bracket	56-5061-9
14	Receiver Mounting	
	a. Bracket	600056-1
	b. Strap	630721-4
	c. Support Bracket	000006721
	d. Base	605865-9
	e. Screw, #10-24 x .50	† 52-0206-9

† Refer to Cross Reference Guide

i1000 PANELS

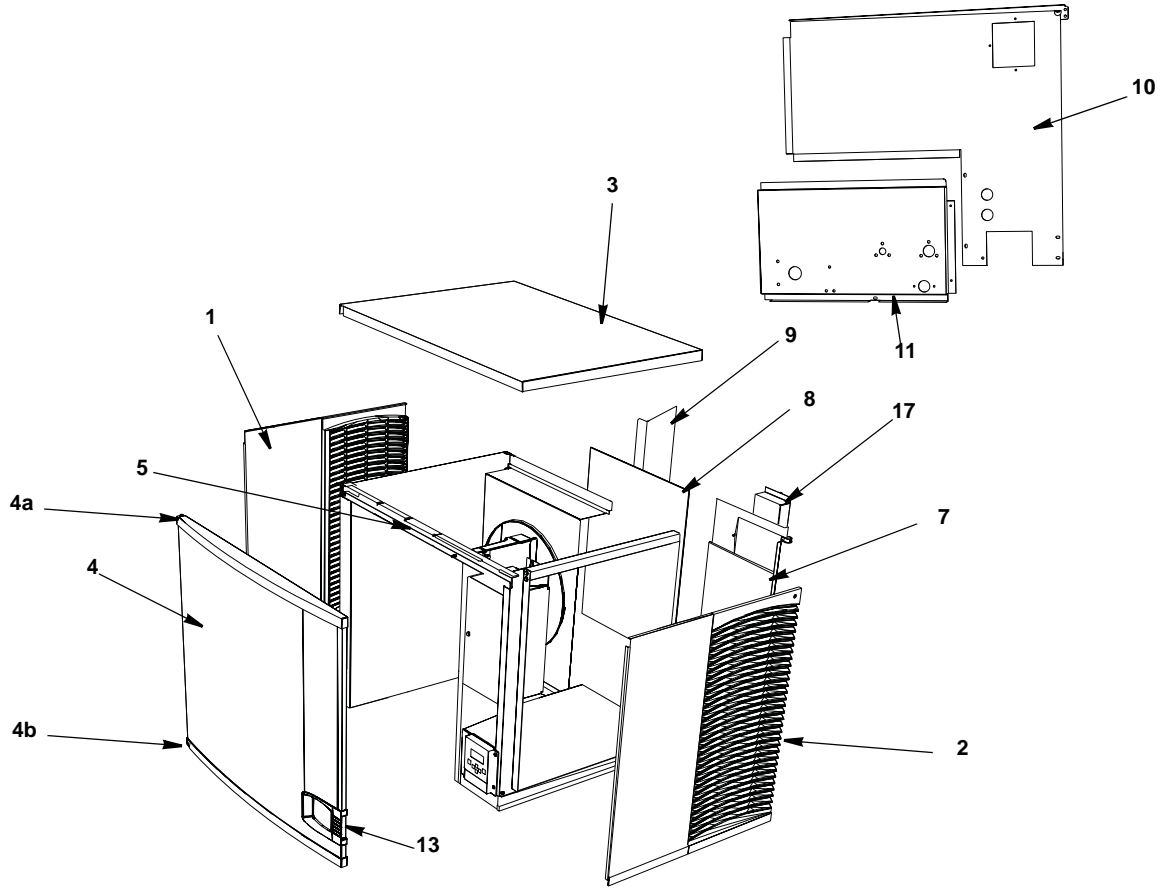

DESCRIPTION

DESCRIPTION	PART NO.
1 Left Side Panel	00005224
2 Right Side Panel	00005222
3 Top Cover	00006699
4 Front Panel Assembly	00006578
a. Top Endcap	00006538
b. Bottom Endcap	00006539
5 Front Top Support	00006730
Mounting Screw Left Side 8-32 x 1	50-0537-9
Mounting Screw Right Side 10-24 x .50	50-0509-9
6 Back Coupling Panel, Drain/Water Connection (Compressor Base)	606170-9
Air-Cooled Back Panels	
7 Back Panel with Electrical Connection Box, Air-cooled Models	00007868
8 Air Filter	30-0555-9
9 Air Baffle Assembly	00007502
Water-Cooled & Remote Air-Cooled Back Panels	
10 Back Panel with Electrical Connection Box	00007870
11 Back Coupling Panel, Water-Cooled/Remote Connections	606173-9
12 Drain Fitting	87-0608-3
Miscellaneous – Brackets, Screws, etc.	
13 Front Panel LCD Frame	
a. With Key Guard	00006647
b. Without Key Guard	00006564
c. Display Cover (hides the display completely)	K00433
14 Door Screw	50-0489-9
15 Bottom Door Frame	76-0226-3
a. Mounting Screw Left Side 8-32 x 1 PHIL	50-0537-9
b. Mounting Screw Right Side 10/24 x .50 PHIL	52-0209-9
16 Left Door Pivot Leaf Hinge (Top or Bottom)	30-0557-9
a. Mounting Screw 8-32 x 1 PHIL	50-0537-9
17 Electrical Connection Box Cover	Included in Back Panel Assembly
18 Left Top Channel	606864-9
19 Right Corner Post	606177-9
20 Right Top Channel	606257-9
21 Electrical Box on Rear of Ice Machine	
a. Box	Included in Back Panel Assembly
b. Terminal Block 3 Pole	20-0614-3
c. Groundscrew #10-24 x .50	52-0216-9

JC995 Remote Condenser

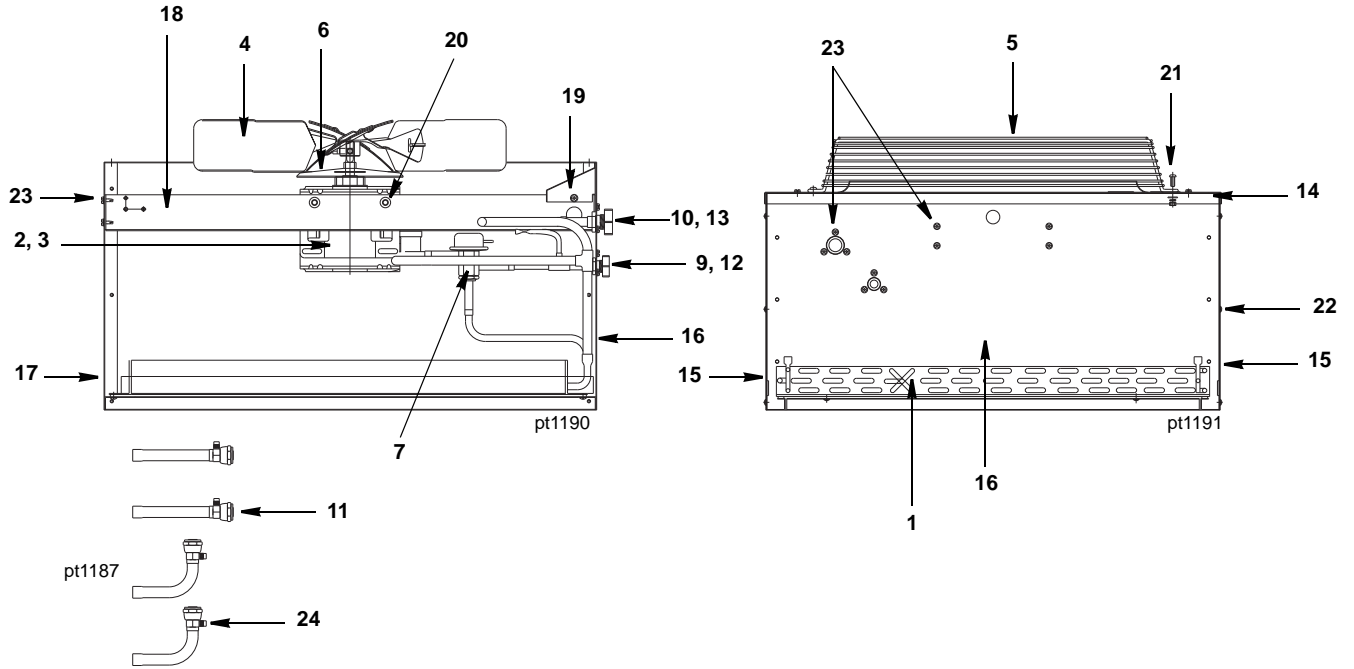

DESCRIPTION

	DESCRIPTION	PART NO.
1	Air Condenser	† 88-5062-9
2	Fan Motor (208-230V 50/60 Hz/1 Ph)	† 76-2941-3
3	Fan Motor Run Capacitor (Emerson)	85-0458-3
4	Fan Blade	24-1611-3
5	Fan Guard	34-0064-3
6	Rain Slinger	24-1505-3
7	Head Pressure Control	000002369
8	Fan Cycle Control	000007580
9	Coupling – Male, 5/8-18	† 83-6034-3
10	Coupling – Male, 1-1/6-12	† 83-6035-3
11	Female Line Set Coupling Kit (Sold as Finished Goods Sales Kit)	Sales K0129

Miscellaneous – Brackets, Screws, etc.

12	Coupling Mounting Flange (for 5/8-18)	83-6005-3
13	Coupling Mounting Flange (for 1-1/16-12)	83-6006-3
14	Top Cover	† 601775-1
15	Panel – Side	† 601774-1
16	Panel – Rear	† 601773-1
17	Panel – Front	† 601772-1
18	Fan Motor Mounting Bracket	† 601768-1
19	Electrical Box Cover	† 601776-1
20	Fan Motor Mounting Screw (5/16-18 x 5/8)	† 50-3565-9
a.	Fan Motor Mounting Flatwasher	† 55-7309-9
b.	Fan Motor Mounting Lockwasher	† 55-7313-9
c.	Fan Motor Mounting Hexnut	54-2975-9
21	Fan Guard Mounting Screw (1/4-20 x 5/8)	† 50-3345-9
a.	Fan Guard Mounting Flatwasher	† 55-7304-9
b.	Fan Guard Mounting Lockwasher	† 55-4511-9
c.	Fan Guard Mounting Hexnut	† 54-2952-9
22	Panel/Condenser Mounting Screw (#8 x 1/2)	† 51-2153-9
a.	Panel/Condenser Mounting Lockwasher	† 55-4459-9
23	Screw (#10-24 x 1/2)	† 52-0206-9
24	Valve Cores (used in linesets)	76-2684-3
25	Legs (Not shown)	† 601769-1

INTENTIONALLY LEFT BLANK