



Ice Machine Parts List for Series i-1800 Models

iR1800A

iY1804A

iR1801W

iY1805W

iR1890N

iY1894N

iD1802A

JC1895

iD1803W

iD1892N

i1800 CONTROL BOX

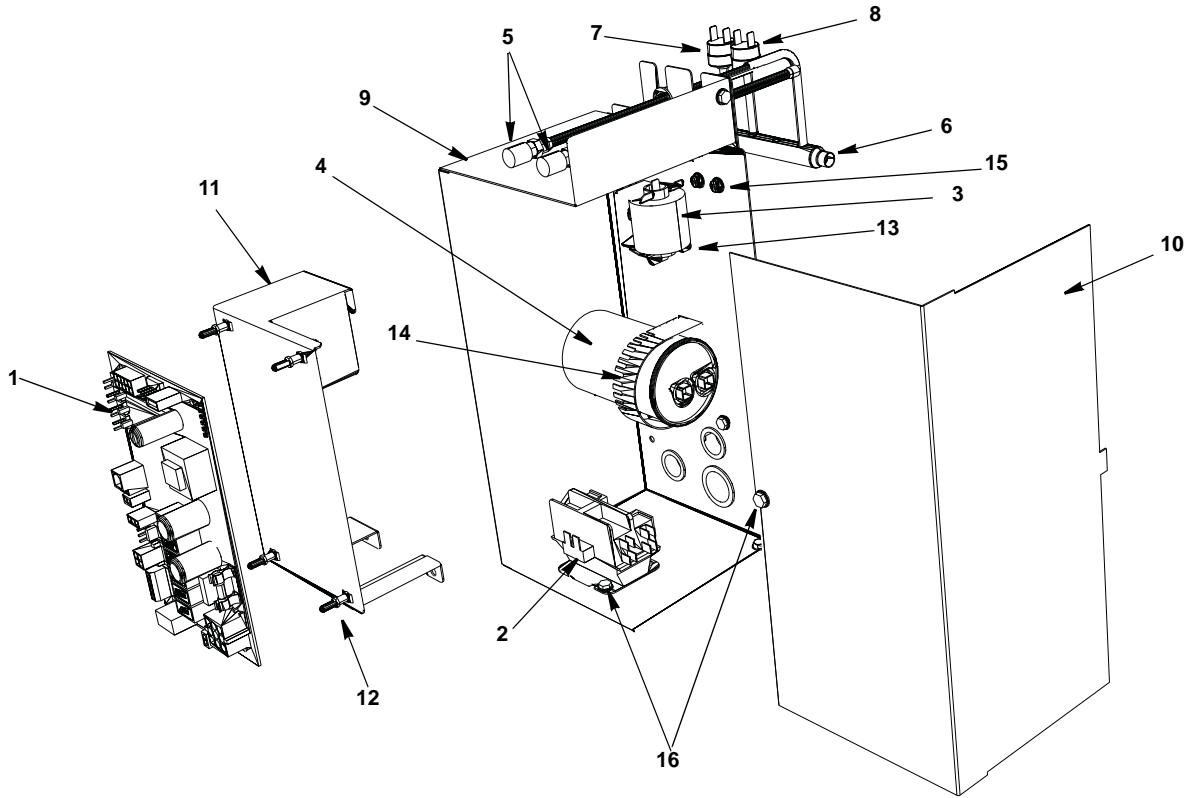

DESCRIPTION

	PART NO.
1 Control Board (for use with all voltages)	000008309
a. 8 amp Ceramic Fuse – Mounted on Control Board	000009181
2 Contactor	
a. 208-230V/60 Hz/1ph	20-0908-9
b. 208-230V/60 Hz/3ph	20-0661-9
c. 230V/50 Hz/1ph	000010003
3 PTCR Compressor Starter	85-0491-3
4 Compressor Run Capacitor	
a. 208-230V/60 Hz/1ph	000005488
b. 208-230V/50 Hz/1ph	000005488
5 Refrigeration Service Valve Assembly	83-7325-3 & 83-7326-3
6 Manifold Strainer	82-5357-9
a. Bracket	605857-1
7 High Pressure Cut-out (Auto Reset)	20-0124-3
8 Fan Cycling Control	20-0127-3
Miscellaneous – Brackets, Screws, etc.	
9 Control Box	000008279
10 Control Box Cover	000007574
11 Control Board Mounting Bracket	000007564
12 Control Board Mounting Supports	43-0225-3
13 PTCR Compressor Starter Mounting Bracket	85-0495-3
14 Capacitor Mounting Bracket	603313-1
15 Screws, #10-24 x .50 Ground	52-0216-9
a. Star Washer	55-7320-9
16 Screw, #10-24 x .50	52-0206-9
17 Lockwashers	55-7320-9
18 Control Box Bushings	
a. Large (1)	25-0001-9
b. Small (4)	25-0140-9
19 Control Box Wiring Harness (Not shown)	
a. 230/60/1	000007752
b. 230/60/3	20-0897-9
c. 230/50/1	000007753
d. 460/60/3	000008020
20 Compressor Compartment Wiring Harness (Not shown)	
a. Air-cooled	000008257
b. Water-cooled	000008258
c. Remote-cooled	000008259
21 Electrical Noise Filter Wiring Harness	
a. 460/60/3	000005500

i1800 EVAPORATOR COMPARTMENT - COMMON COMPONENTS

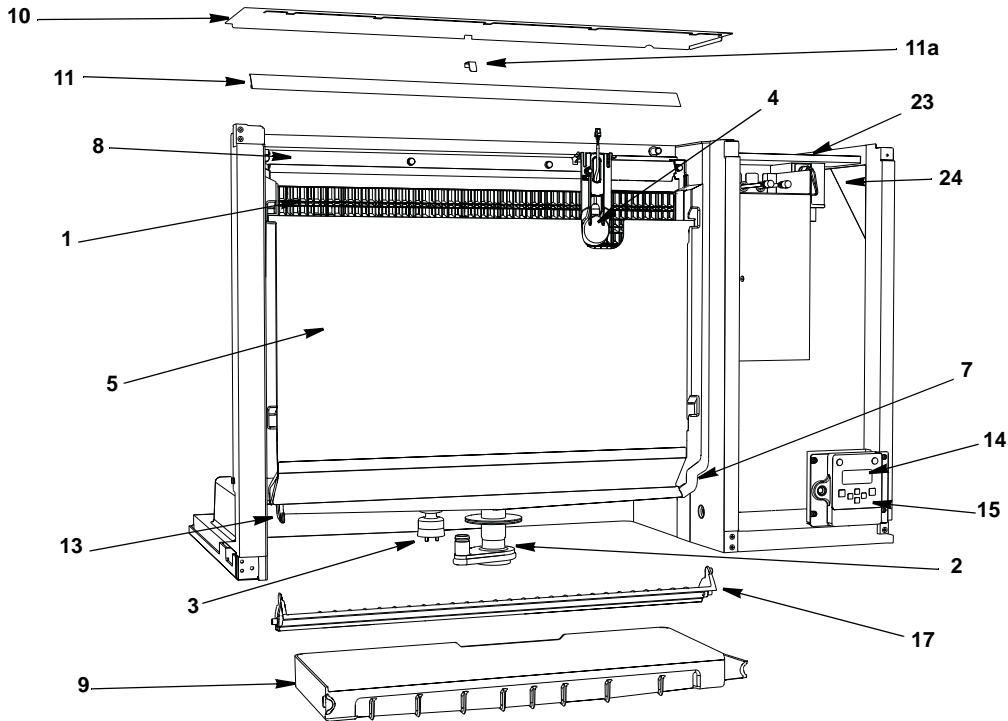

DESCRIPTION

PART NO.

1	Evaporator Assembly	
	a. Dice Cube	
	b. Half Dice Cube	
	c. Regular Cube	
2	Water Pump	
	a. 230V/60 Hz 1/3PH	82-5270-9
	b. 230/50/1	00000259
3	Water Level Probe.	000007052
	a. Wire, control box to probe (Not shown).	000007724
	b. Holder	000007053
	c. Screw (Mount Water Level Probe Holder)	52-0209-9
4	Ice Thickness Control Probe.	000008660
5	Splash Shield	
6	Ice Damper Assembly.	000008110
7	Magnetic Bin Switch.	000007888
	a. Wiring Harness	000007410
8	Water Distribution Tube Assembly	76-0319-3
	a. O-Rings (Back of Distribution Assembly)	50-0464-9
9	Water Trough	000009112
10	Foodzone Seal Panel	000008253
11	Evaporator Top Filler Panel	000008805
	a. Stainless Steel Clamp	606333-9
	b. Clamp Screw	52-0209-9
12	Evaporator Top Frame Assembly	
13	Evaporator Bottom Frame Assembly	
14	LCD Display	000006728
15	Touch Pad with Housing	000007926
16	LCD Wiring Harness (Not shown).	000007737
17	Touch Pad/Housing Mounting Bracket	000008091
18	Front Panel LCD Frame	
	a. With Key Guard.	000008090
	b. Without Key Guard	000008089
	c. Display Cover (hides the display completely)	K00433
Miscellaneous – Brackets, Screws, etc.		
19	Screw, (Water Distribution Tube Mounting) Each	50-0479-9
	a. O-Ring.	50-0462-9
20	Screw, #12-16 x .687 Used to Mount Evaporator (Each)	50-0461-9
21	Water Pump Base O-Ring	50-0465-9
22	Water Pump Outlet O-Ring.	50-0467-9
23	Support Bracket	000008710
24	Angled Support Bracket	000008712

i1800 REFRIGERATION COMPARTMENT – COMMON PARTS

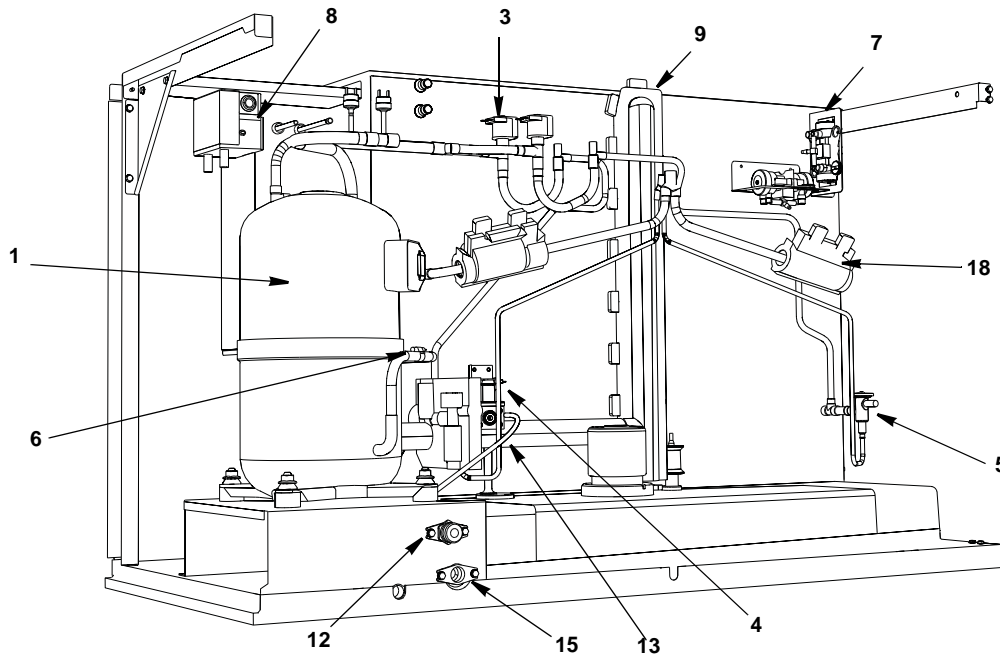

DESCRIPTION

PART NO.

1 Compressor	
a. 208-230V/60 Hz/1 Ph	000008445
b. 208-230V/60 Hz/3 Ph	000008446
c. 230V/50 Hz/1 Ph	000008447
d. 460V/60 Hz/3 Ph	000008448
e. Molded Plug	000005176
2 Water Dump Valve (with bracket)	
a. Dump Valve, 208-230V/50-60 Hz	000001768
b. Mounting Bracket	605845-9
c. Dump Valve Tubing 3.25 inches	44-2038-3
3 Harvest Valve	
a. Harvest Valve Including 208/230V 50/60 Hz Electrical Coil	000007017
b. Harvest Valve 208/230V Coil Only Danfoss	000005157
4 Water Inlet Valve	
a. Water Inlet Valve Including 208-230V/50-60 Hz Coil	000007966
b. Water Inlet Valve Bracket	000008582
5 Expansion Valve	
a. Expansion Valve Body Insulation Boot	76-0225-3
b. Expansion Valve Bulb Insulation Boot	40-1329-9
6 Thermistors with Spring Clips	
7 Air Assist	
a. 230V with brackets	000007223
b. Manifold Tee (Air Pump Tubing Outlet)	40-1173-9
c. Bracket	000006489
d. Nozzle	30-0145-3
8 LuminIce	
a. LuminIce Bulb	K00434
b. LuminIce Wiring Harness	K00425
c. Bulkhead Fitting 2.25"	000007409
d. Bulkhead Fitting 2.75"	000007990
9 Insulated Tube (vinyl tubing from distribution tube to water pump & dump valve)	
a. Clamp 0.859/0.989 ID	000008269
b. Clamp 0.799/0.899 ID	000003409
10 Vinyl Tubing 0.625 ID (dump valve to drain adapter)	
a. Insulation	56-5060-9
b. Clamp	56-5070-9
11 Heat Exchanger	
Miscellaneous – Brackets, Screws, etc.	
12 Water Inlet Wing Adapter	
a. Adapter Plastic Fitting	000001382
13 Water Inlet Valve Tubing	
14 Connector Water Inlet Valve	
15 Water Drain Wing Adapter	
16 Compressor Mounting	
a. Base	603883-1
b. Rubber Grommet	56-5070-9
c. Sleeve	000009316
d. Bolt	87-0609-3
e. Nut	13-6096-1
17 Clamp, Expansion Valve Bulb	
18 Copper Bulb Strap	
19 Screw, #10-24 x .50	

i1800 REFRIGERATION COMPARTMENT – AIR-COOLED

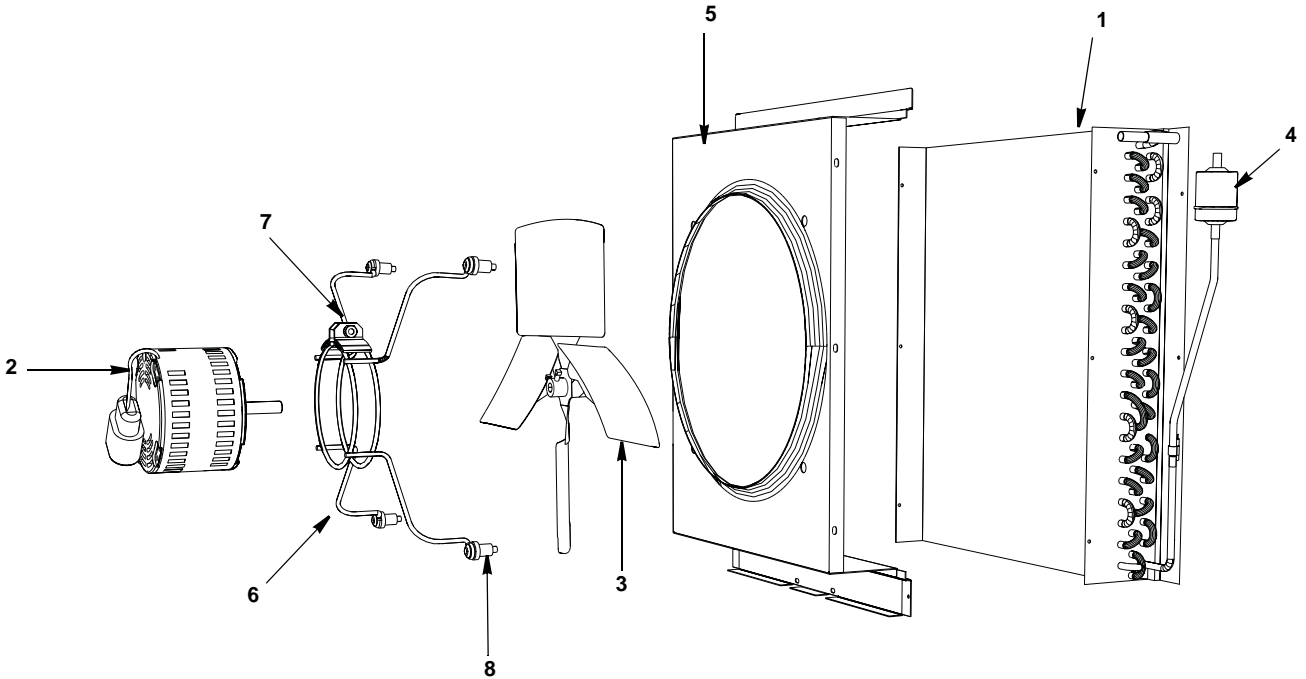

DESCRIPTION

	DESCRIPTION	PART NO.
1	Air Condenser	88-5129-3
2	Fan Motor (208-230V/60 Hz or 230V/50 Hz)	76-2673-3
3	Fan Blade	24-1611-3
4	Drier	89-3027-9

Miscellaneous – Brackets, Screws, etc.

5	Fan Shroud	606597-9
6	Fan Motor Bracket	30-0682-3
7	Fan Motor Mounting	
	a. Screw	† 50-3358-9
	b. Lockwasher	† 55-4510-9
	c. Hexnut	† 54-2952-9
8	Fan Bracket Mounting	
	a. Screw	50-3238-9
	b. Lockwasher	† 55-4510-9
	c. Flatwasher	† 55-7305-9
	d. Rubber Wellnut	† 54-2955-9
9	Screw, #10-24 x .50	† 52-0206-9

† Refer to Cross Reference Guide

i1800 REFRIGERATION COMPARTMENT – WATER-COOLED

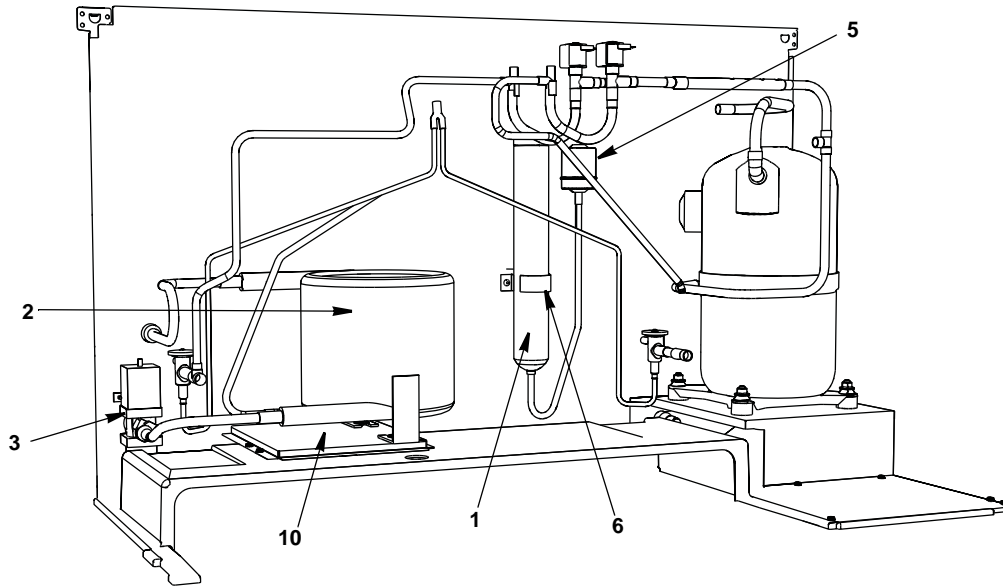

DESCRIPTION

DESCRIPTION	PART NO.
1 Receiver	76-2092-3
2 Water-cooled Condenser	000001508
3 Water Regulating Valve	83-7212-3
4 Condenser Water Drain Female Wing Adapter	87-0608-3
5 Drier	89-3027-9

Miscellaneous – Brackets, Screws, etc.

6 Receiver Strap	600054-1
7 Elbow .50 MF x .375 MPT	50-0224-9
8 Screw, #10-24 x .50	52-0206-9
9 Washer	55-7341-9
10 Base, Water Condenser/Receiver	606684-9

i1800 REFRIGERATION COMPARTMENT – REMOTE

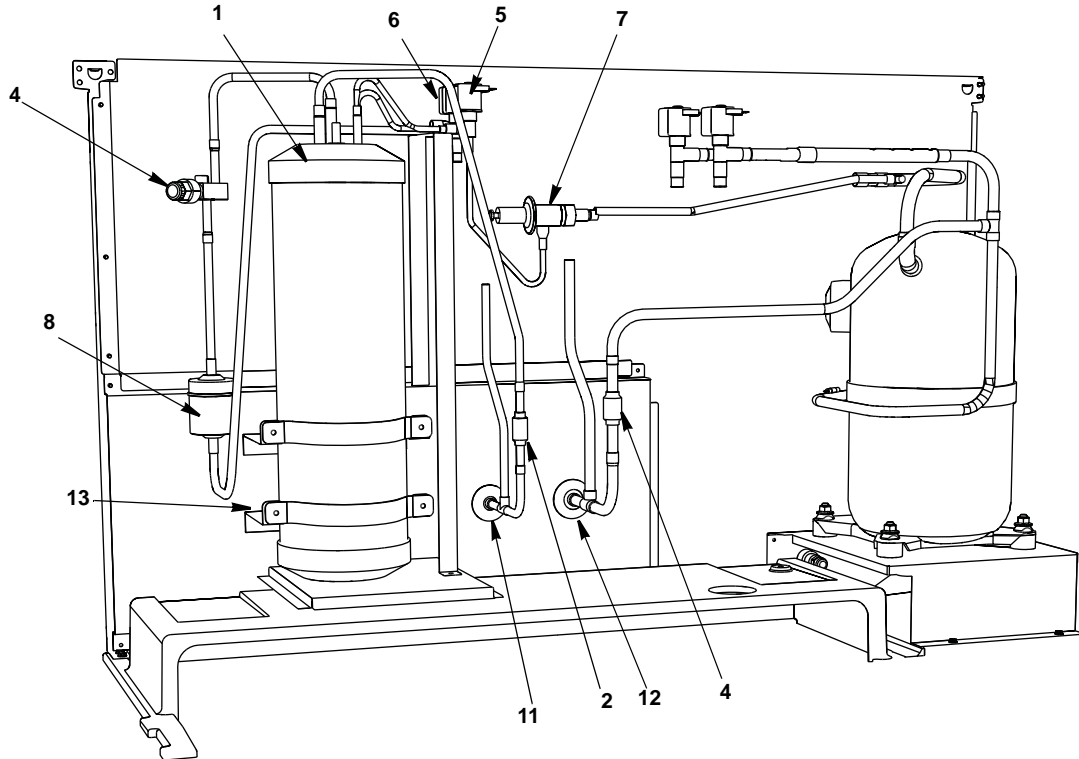

DESCRIPTION

	DESCRIPTION	PART NO.
1	Receiver	76-2958-3
2	Magni-Check Valve	† 83-7314-9
3	Check Valve	† 83-7315-9
4	Refrigeration Service Valve	† 83-7316-9
	a. Cap for Refrigeration Service Valve	56-5075-9
5	Harvest Pressure Regulating Solenoid (HPR) Valve	
	a. HPR Valve Including 208/230V 50/60 Hz Electrical Coil (Danfoss)	000007034
	b. HPR Valve 208/230V 50/60 Hz Coil Only Danfoss	000005157
6	Liquid Line Solenoid (LLS) Valve	
	a. LLS Valve Including 208/230V 50/60 Hz Electrical Coil (Danfoss)	000007026
	b. LLS Valve 208/230V 50/60 Hz Coil Only Danfoss	000005157
7	Harvest Pressure Regulating Valve (HPR)	† 83-6779-3
8	Drier	89-3027-9
9	Coupling – Male, 5/8-18	† 83-6034-3
10	Coupling – Male, 1-1/6-12	† 83-6035-3

Miscellaneous – Brackets, Screws, etc.

11	Coupling Mounting Flange for 5/8-18	83-6005-3
12	Coupling Mounting Flange for 1-1/16-12	83-6006-3
13	Receiver Mounting	
	a. Bracket	600056-1
	b. Strap	630721-4
	c. Support Bracket	000006704
	d. Base	606684-9
	e. Screw, #10-24 x .50	† 52-0206-9

† Refer to Cross Reference Guide

i1800 PANELS

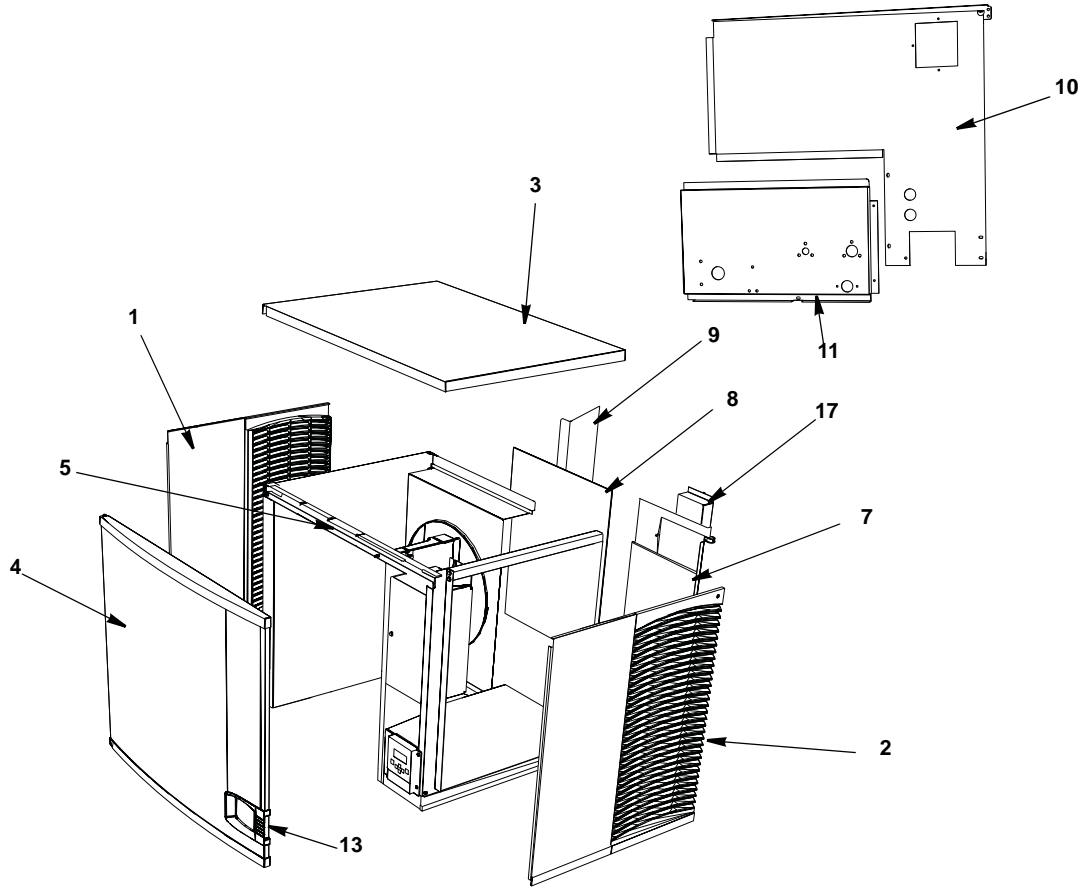

DESCRIPTION

	PART NO.
1 Left Side Panel	000005239
2 Right Side Panel	000005237
3 Top Cover	000008537
a. Bracket	000009932
4 Front Panel Assembly	000008080
a. Top Endcap	000008082
b. Bottom Endcap	000008083
5 Front Top Support	000008263
Cover	000009113
Mounting Screw Left Side 8-32 x 1	50-0537-9
Mounting Screw Right Side 10-24 x .50	50-0509-9
6 Back Coupling Panel, Drain/Water Connection (Compressor Base)	606590-9
Air-Cooled Back Panels	
7 Back Panel with Electrical Connection Box, Air-cooled Models	000008267
8 Air Filter	40-4025-3
9 Air Baffle Assembly	000007678
Water-Cooled & Remote Air-Cooled Back Panels	
10 Back Panel with Electrical Connection Box,	606714-9
11 Back Coupling Panel, Water-Cooled/Remote Connections	606682-9
12 Drain Fitting	87-0608-3
Miscellaneous – Brackets, Screws, etc.	
13 Front Panel LCD Frame	000008090
a. With Key Guard	000008089
b. Without Key Guard	K00433
c. Display Cover (hides the display completely)	50-0489-9
14 Front Panel Screw	000008978
15 Bottom Door Frame	50-0537-9
a. Mounting Screw Left Side 8-32 x 1 PHIL	52-0209-9
b. Mounting Screw Right Side 10/24 x .50 PHIL	000007900
16 Front Panel Mounting Bracket	50-2673-9
a. Mounting Screw 8-32 x .50 Phil	606729-9
17 Electrical Connection Box Cover	606599-9
18 Left Corner Post - Back	606864-9
19 Left Top Channel	000008717
20 Right Corner Post - Front	000008715
21 Right Top Channel	606728-9
22 Electrical Box on Rear of Ice Machine	20-0614-3
a. Box	52-0216-9
b. Terminal Block 3 Pole	
c. Groundscrew #10-24 x .50	

JC1895 Remote Condenser

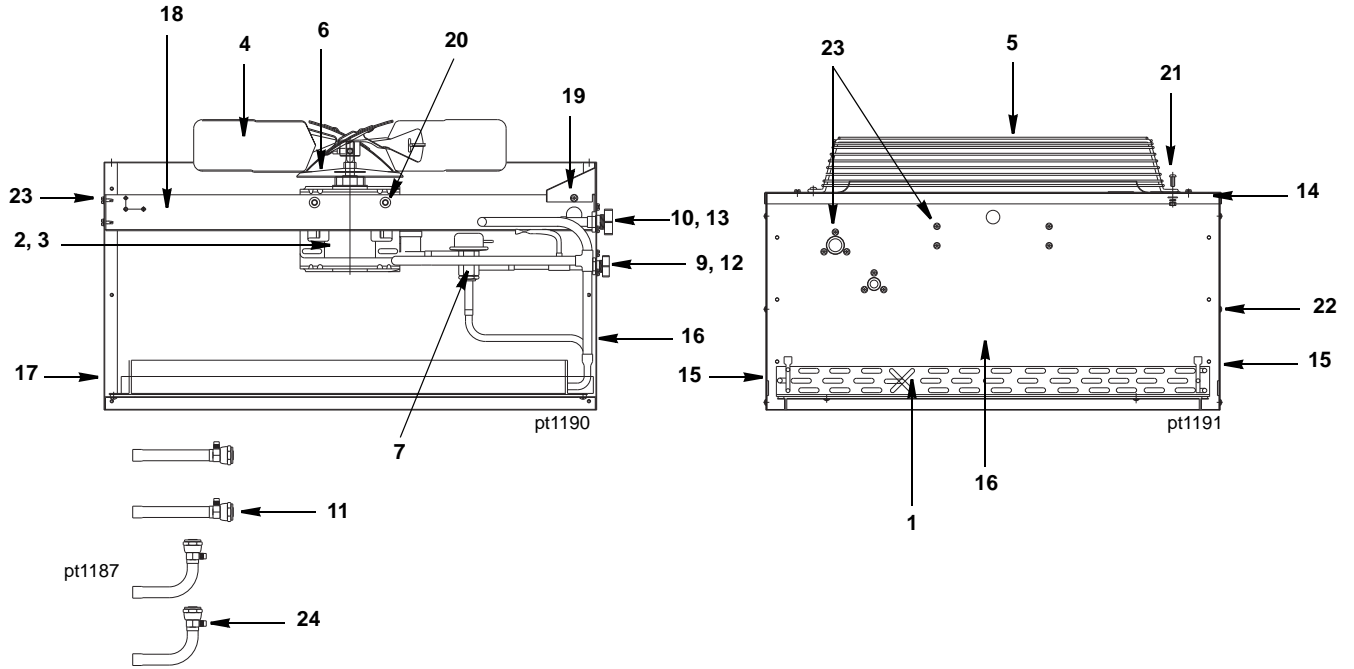

DESCRIPTION

	PART NO.
1 Air Condenser	† 88-5062-9
2 Fan Motor (208-230V 50/60 Hz/1 Ph)	† 76-2941-3
3 Fan Motor Run Capacitor (Emerson)	85-0458-3
4 Fan Blade	24-1611-3
5 Fan Guard	34-0064-3
6 Rain Slinger	24-1505-3
7 Head Pressure Control	000002369
8 Fan Cycle Control	000007580
9 Coupling – Male, 5/8-18	† 83-6034-3
10 Coupling – Male, 1-1/6-12	† 83-6035-3
11 Female Line Set Coupling Kit (Sold as Finished Goods Sales Kit)	Sales K0129

Miscellaneous – Brackets, Screws, etc.

12 Coupling Mounting Flange (for 5/8-18)	83-6005-3
13 Coupling Mounting Flange (for 1-1/16-12)	83-6006-3
14 Top Cover	† 601775-1
15 Panel – Side	† 601774-1
16 Panel – Rear	† 601773-1
17 Panel – Front	† 601772-1
18 Fan Motor Mounting Bracket	† 601768-1
19 Electrical Box Cover	† 601776-1
20 Fan Motor Mounting Screw (5/16-18 x 5/8)	† 50-3565-9
a. Fan Motor Mounting Flatwasher	† 55-7309-9
b. Fan Motor Mounting Lockwasher	† 55-7313-9
c. Fan Motor Mounting Hexnut	54-2975-9
21 Fan Guard Mounting Screw (1/4-20 x 5/8)	† 50-3345-9
a. Fan Guard Mounting Flatwasher	† 55-7304-9
b. Fan Guard Mounting Lockwasher	† 55-4511-9
c. Fan Guard Mounting Hexnut	† 54-2952-9
22 Panel/Condenser Mounting Screw (#8 x 1/2)	† 51-2153-9
a. Panel/Condenser Mounting Lockwasher	† 55-4459-9
23 Screw (#10-24 x 1/2)	† 52-0206-9
24 Valve Cores (used in linesets)	76-2684-3
25 Legs (Not shown)	† 601769-1

INTENTIONALLY LEFT BLANK